

# ocean master & plantation MAX F-1

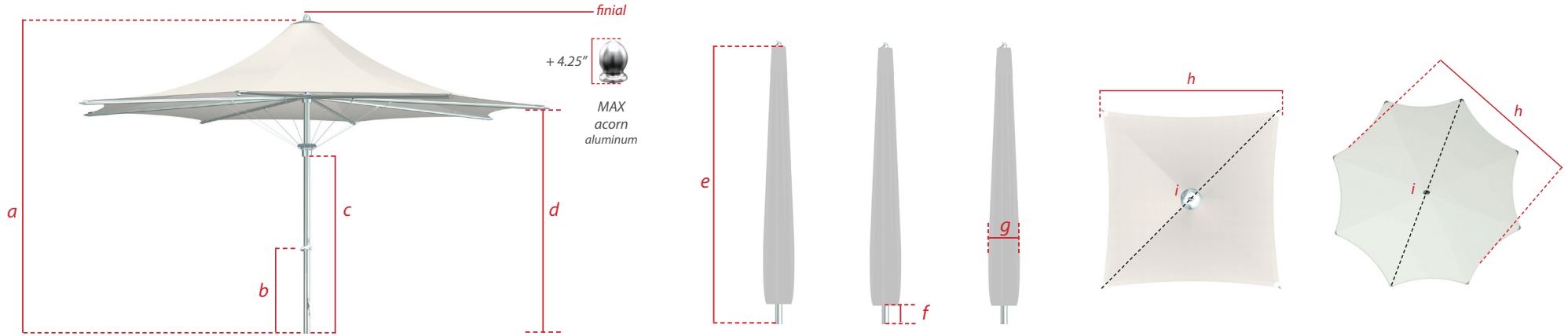

	sizes [ft/m]	Pole Diameter	mast height (open position) a (in/cm)	crank clearance b (in/cm)	hub clearance c (in/cm)	canopy clearance d (in/cm)	mast height (closed position) e (in/cm)	table clearance f (in/cm)	closed parasol width g (in/cm)	flat to flat (Open Umbrella) h (in/cm)	point to point i (in/cm)	canopy area coverage ft <sup>2</sup> / m <sup>2</sup>
<b>classic</b>												
<b>square</b>	13.0' / 4.0m	2 7/8	156 / 396	32.5 / 83	85 / 216	101 / 257	126 / 320	7 / 18	14 / 36	155 / 394	218 / 554	167 / 15.5
<b>octagon</b>	18.0' / 5.5m	2 7/8	149 / 378	32.5 / 83	85 / 216	100 / 254	121 / 307	7 / 18	19 / 48	201 / 511	218 / 554	236 / 21.9

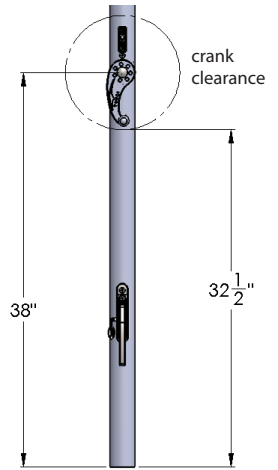

## finish options:

### ocean master classic

#### standard

#### powder coat



### plantation classic



#### vent and pocket options

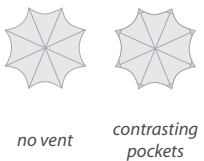

#### profile



#### canopy options



#### panel options

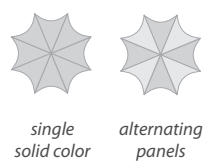

#### lifting system



#### finial



#### mast finish



Dimension Tolerances ± 2"  
Dimensions shown correspond to indicated lift system  
Options are subject to change without notice  
Some options are only available in certain sizes and shapes

2" security base stem height not included