



Elevation

Specification Guide

Elevation

It's time to get moving.

The Elevation height-adjustable workstation and table system is here to expand your possibilities, with the flexibility to suit every requirement.

Elevation

Electric

6 – 9

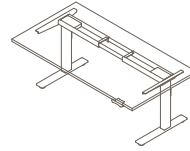

Manual

10 – 12

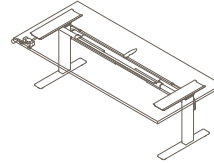

Accessories

13 – 16

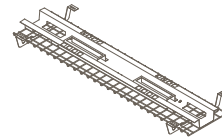

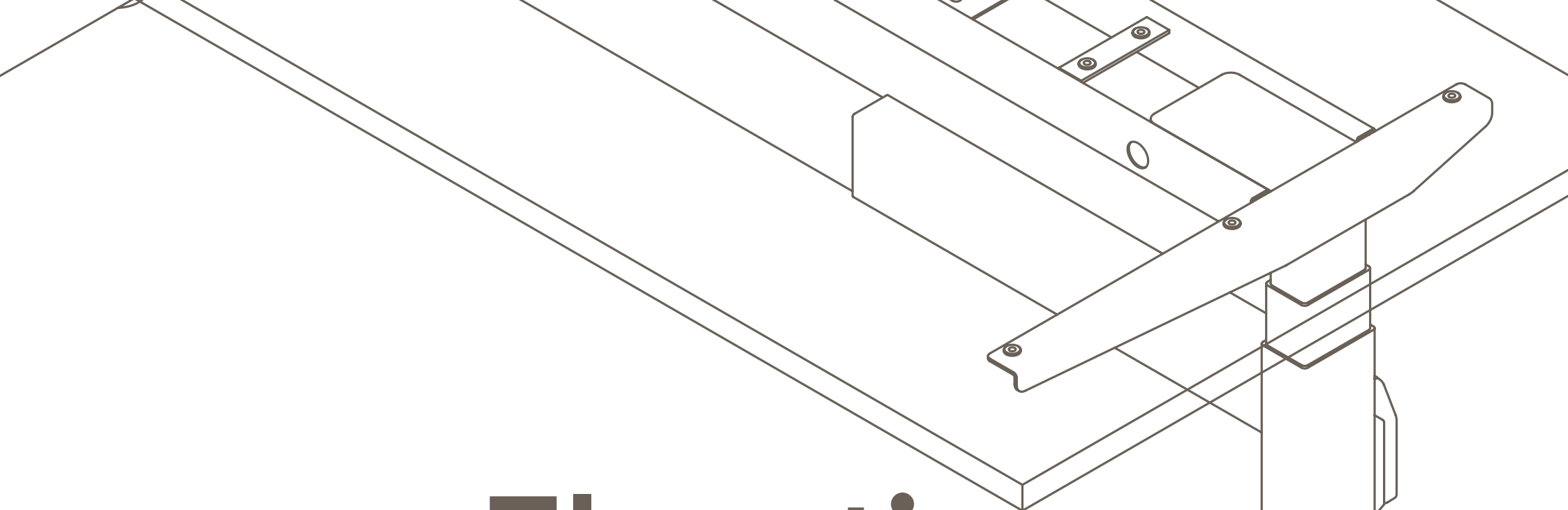

Elevation

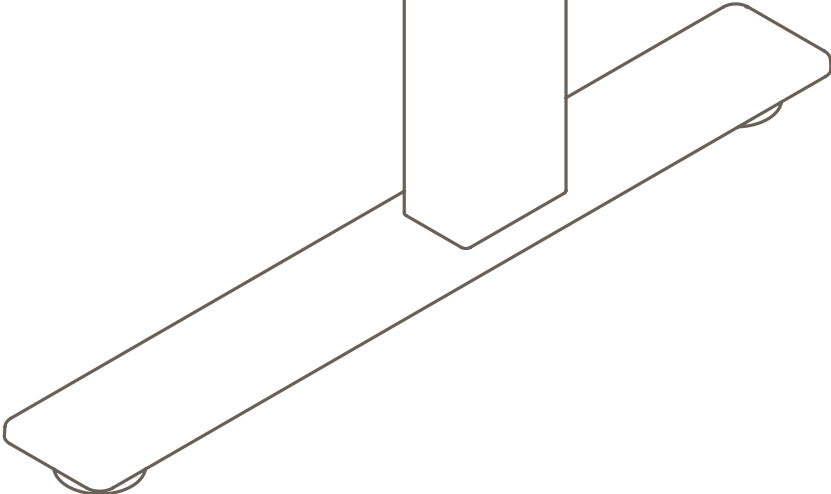

Elevation

General Features

Dimensions

Minimum Height	625mm
Maximum Height (to underside of worktop)	1275mm

Function

- 4x Height Presets (handset programmable)
-

Warranty

Electric Frame	10yrs
Electrical Components	5yrs

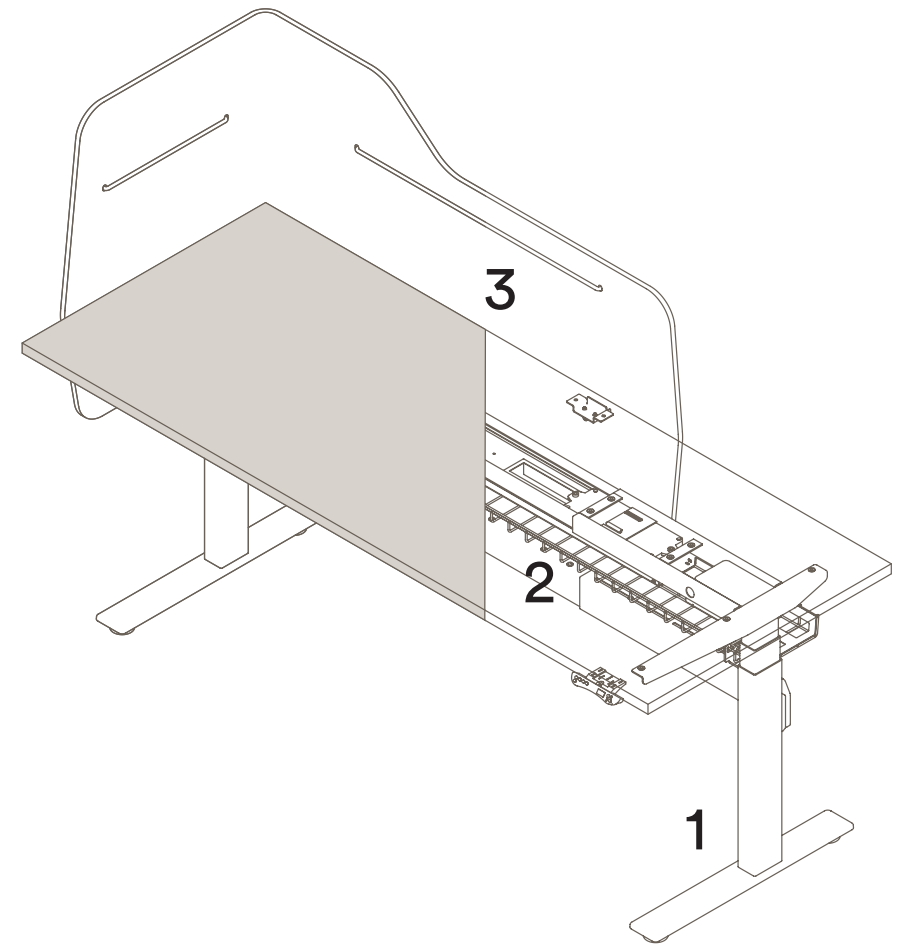

Colours are representative only, please check with your Thinking Works consultant to view samples of any specific colour.

Elevation Finishes

1. Frame Powdercoat

Elevation steel and aluminium frame is available in Black, Silver and White powdercoat.



2. Cable Basket

Our cable management basket comes standard as Black powdercoat.

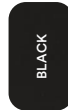

3. Acoustic Wrap Screen

Our unique mobile and reversible wrap screen is available in Light Grey and Dark Grey acoustic panel.

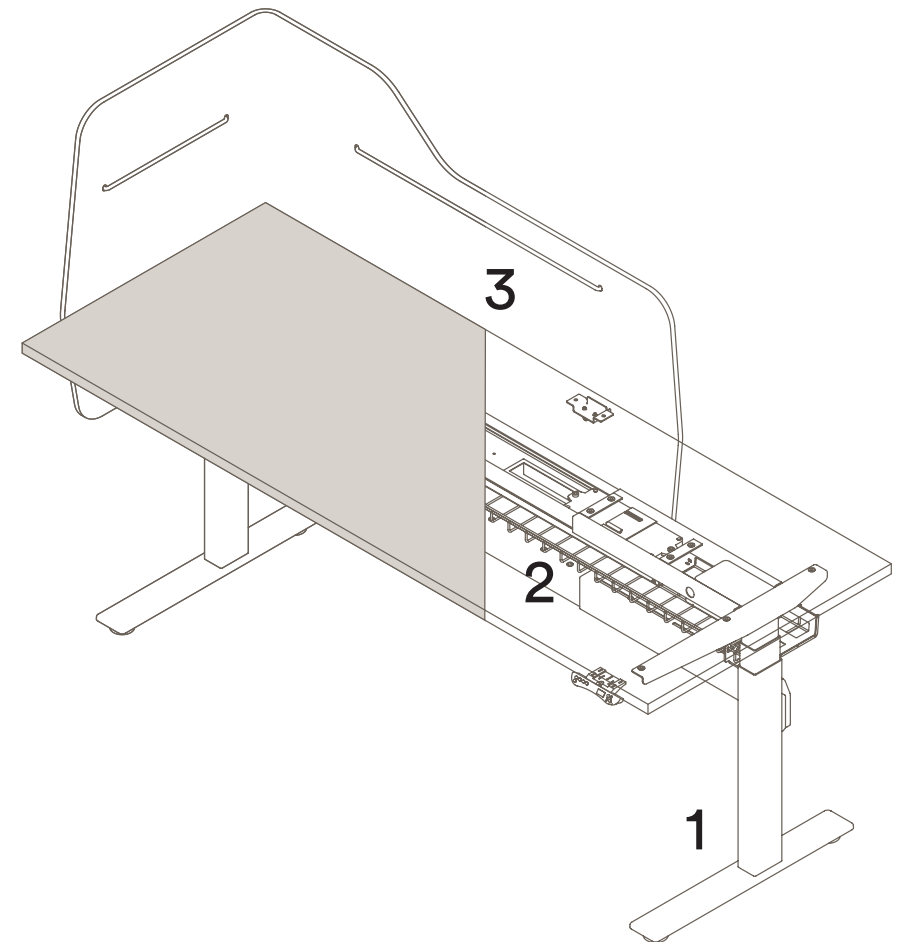

Colours are representative only, please check with your Thinking Works consultant to view samples of any specific colour.

Electric Single Sided

Materials Information

Leg & Foot Finish

Powdercoat Steel Leg & Foot

- a. White
- b. Silver
- c. Black

Frame Finish

Powdercoat Steel Frame

- a. White
- b. Silver
- c. Black

Controller Finish

Black Control Box & Handset

Additional Frame Cross-Beam

Optional for Electric Single Sided 1200-2100mmWP

Optional for Electric 90/120deg 1400-1800mmWP

Required for Electric 90/120deg 1801-2100mmWP

Height Range

600mm to 1250mm to underside of worktop

Travel Speed

35/mm per second

Glide Adjustment

Plus or minus 5mm

Handset

4 programmable height settings with electronic display

Maximum inc. worktop	100kg
Maximum Point Load	30kg
Seats	1

E2S-1000 1pax

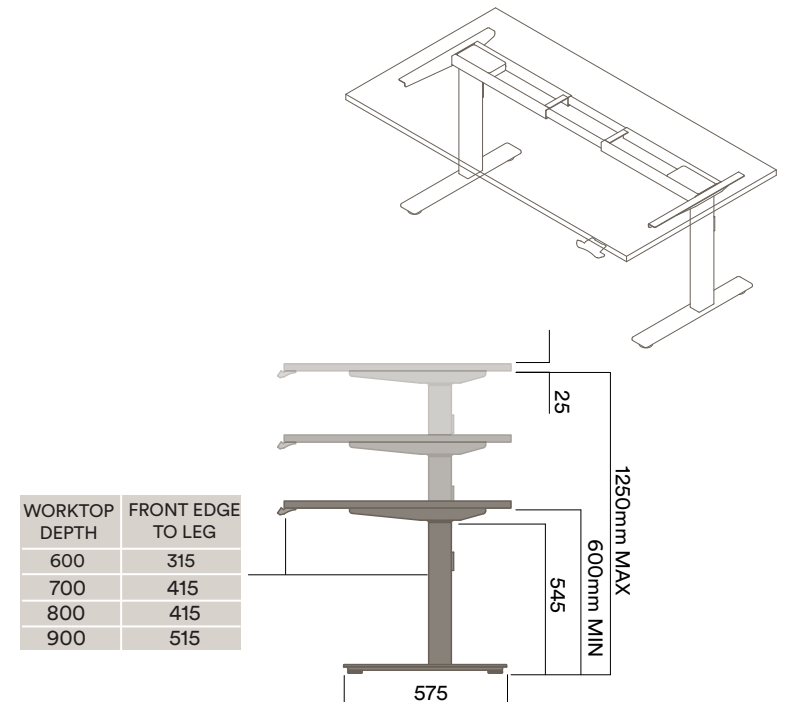
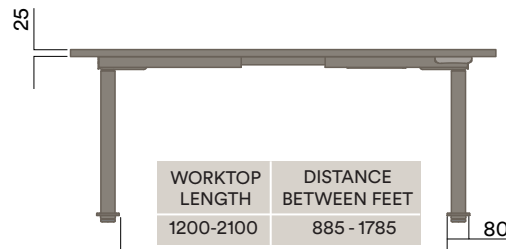
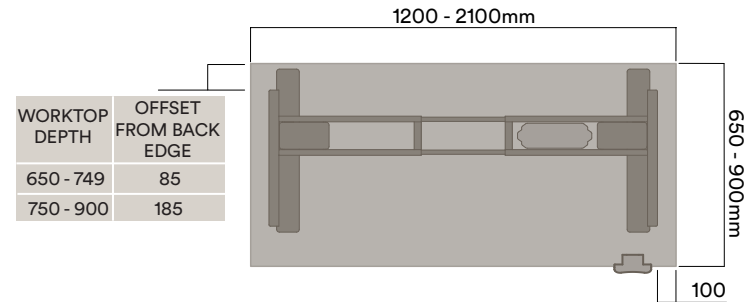

E2S-1090 1pax 90deg

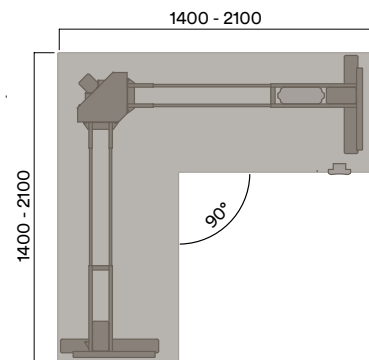

E2S-1120 1pax 120deg

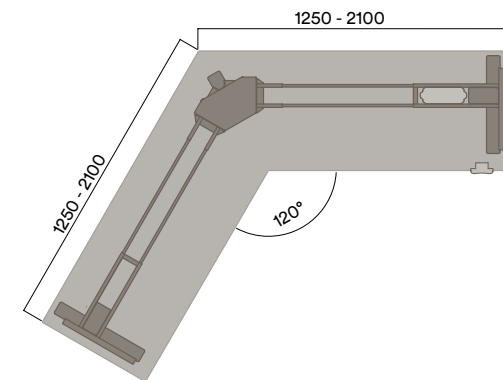

Electric Double Sided

Materials Information

Leg & Foot Finish

Powdercoat Steel Leg & Foot

- a. White
- b. Silver
- c. Black

Frame Finish

Powdercoat Steel Frame

- a. White
- b. Silver
- c. Black

Controller Finish

Black Control Box & Handset

Height Range

600mm to 1250mm to underside of worktop

Travel Speed

35/mm per second

Glide Adjustment

Plus or minus 5mm

Handset

4 programmable height settings with electronic display

*Gap between worktop depending on screen thickness

Maximum inc. worktop 150kg
 Maximum Point Load 30kg
 Seats 2

E2S-1050 Meeting Table

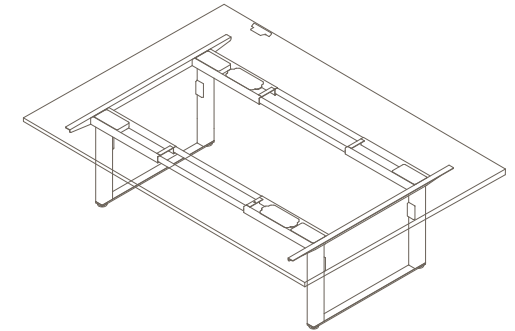
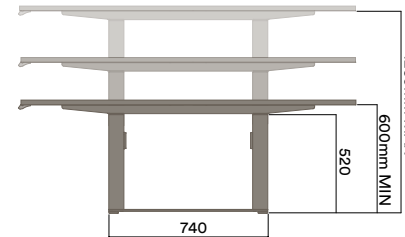
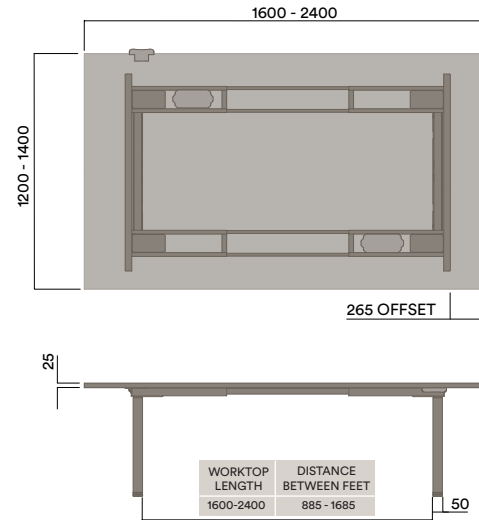

E2S-2000 2pax H-Frame

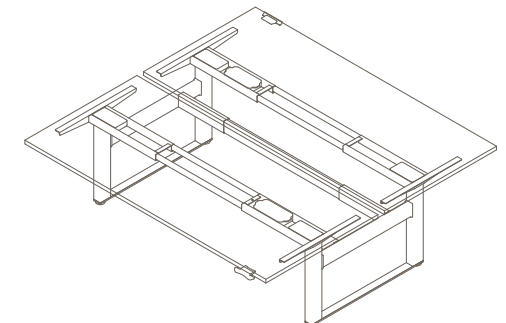
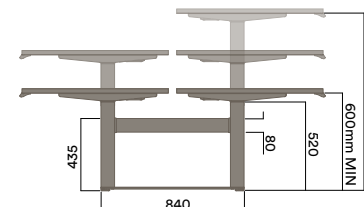
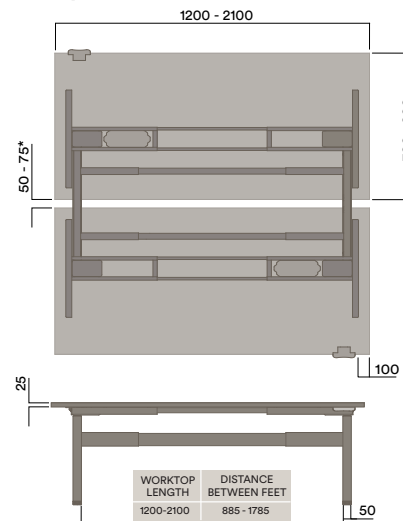

Electric Double Sided

Materials Information

Leg & Foot Finish

Powdercoat Steel Leg & Aluminium Foot

- a. White
- b. Silver
- c. Black

Frame Finish

Powdercoat Steel Frame

- a. White
- b. Silver
- c. Black

Controller Finish

Black Control Box & Handset

Height Range

600mm to 1250mm to underside of worktop

Travel Speed

35/mm per second

Glide Adjustment

Plus or minus 5mm

Handset

4 programmable height settings with electronic display

*Gap between worktop depending on screen thickness

Maximum inc. worktop	150kg
Maximum Point Load	30kg
Seats	3 - 4

E2S-3000 3pax

120deg H-Frame

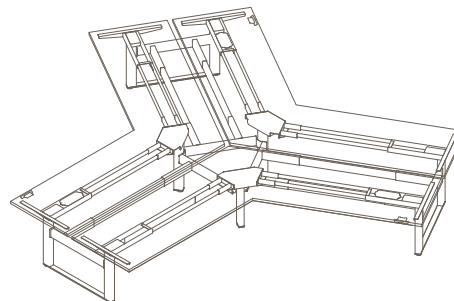
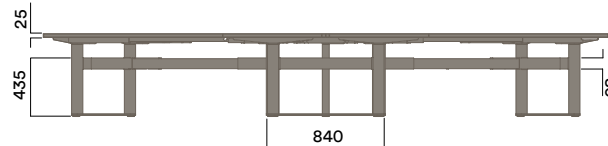
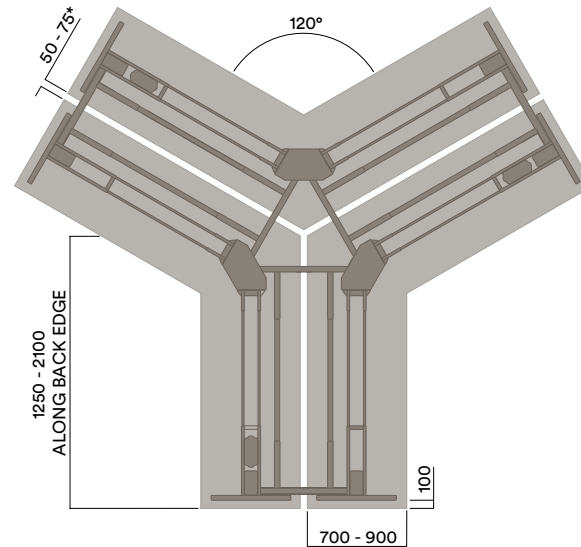

E2S-4000 4pax

90deg H-Frame

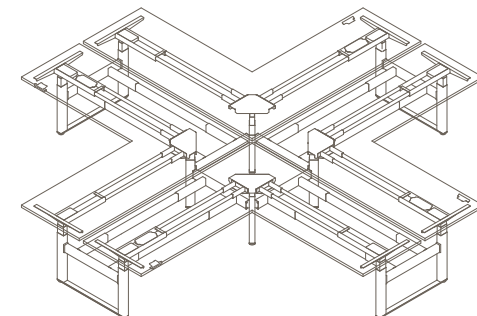
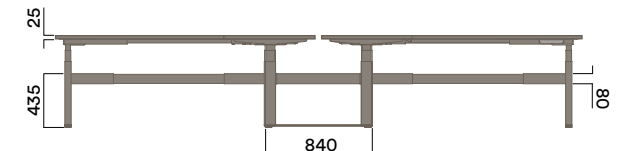
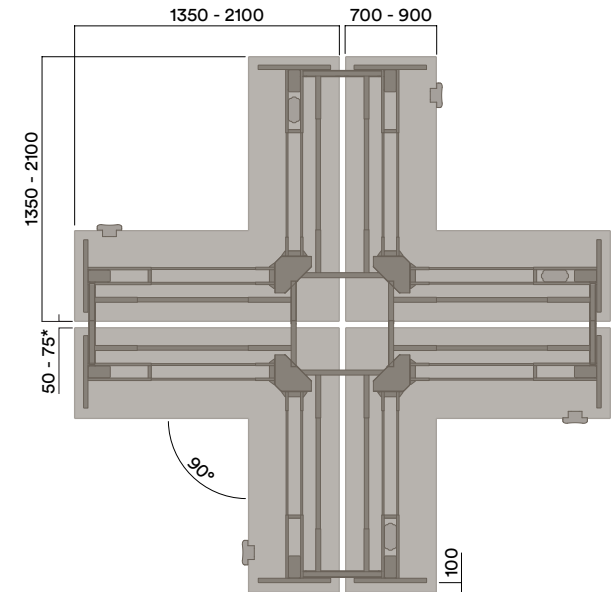

Electric Safety Features

Impact Stop

- Impact Stop system minimises damage to Electric Height Adjustable frames from contact with objects obstructing the path of movement
- Impact Stop initiates while frame is lowering or raising, when 1 second of resistance from an obstruction is detected.
- When resistance is detected, desk will automatically stop then move 50mm in opposite direction in order to clear obstruction.

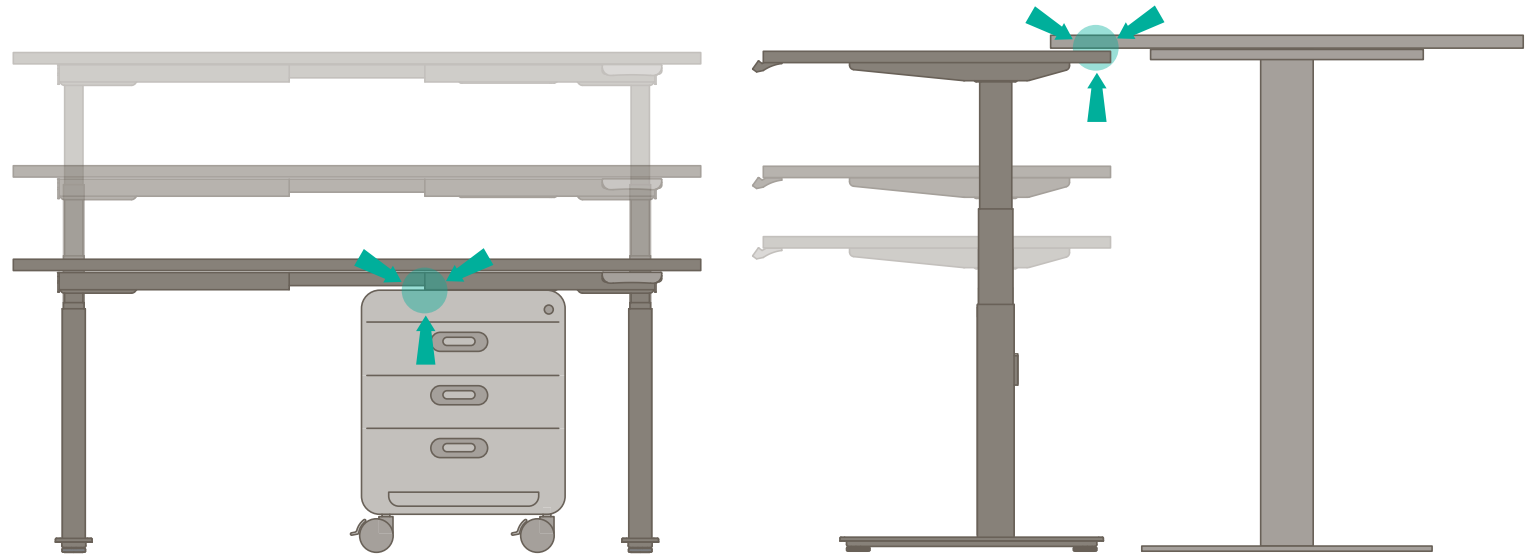

Manual Single Sided

Materials Information

Leg & Foot Finish

Powdercoat Steel Leg & Foot

- a. White
- b. Silver
- c. Black

Frame Finish

Powdercoat Steel Frame

- a. White
- b. Silver
- c. Black

Winder Finish

Black Plastic Winder Handle

Height Range

585mm to 885mm to underside of worktop

Travel

Winder (left or right position)

OR

Technician Adjustable (Winder frame with handle removed)

Travel Speed

2.5/mm per turn, 145 turns from 585mm to 885mm

Glide Adjustment

Plus or minus 5mm

Maximum inc. worktop 100kg
 Maximum Point Load 30kg
 Seats 1

E2-1000 1pax

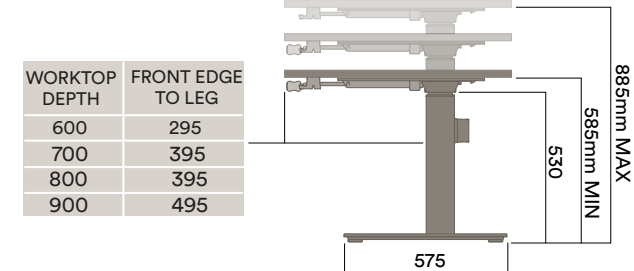
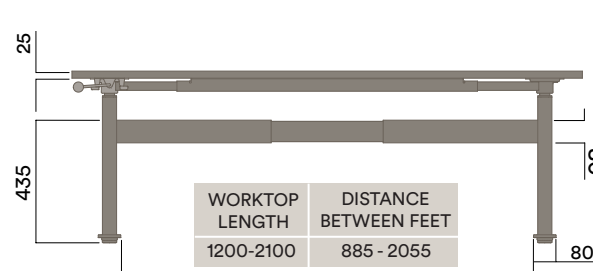
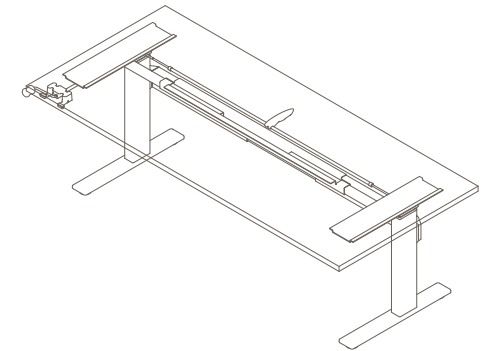
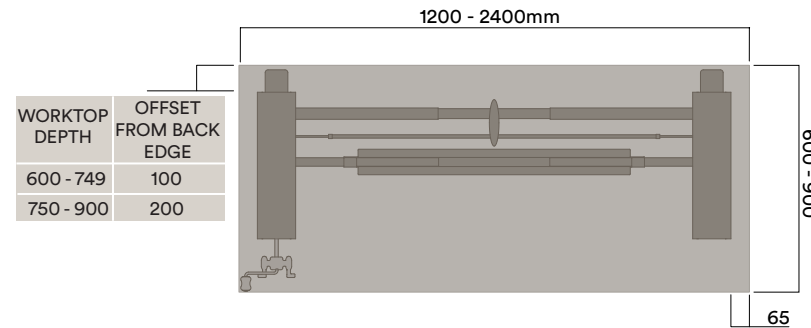

E2-1090 1pax 90deg

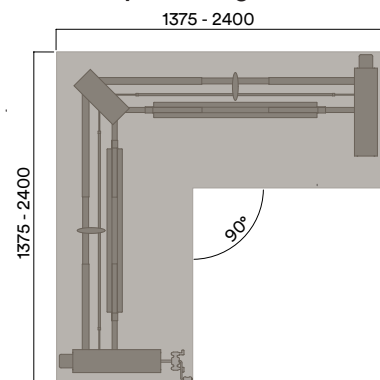

E2-1120 1pax 120deg

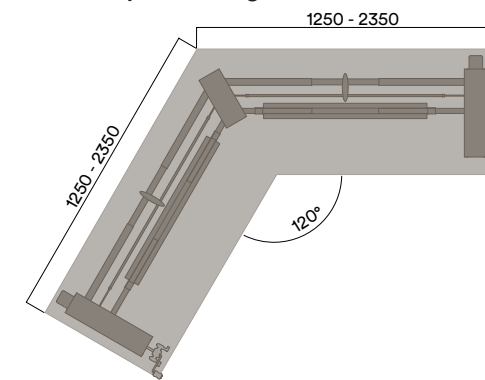

Manual Double Sided

Materials Information

Leg & Foot Finish

Powdercoat Steel Leg & Aluminium Foot

- a. White
- b. Silver
- c. Black

Frame Finish

Powdercoat Steel Frame

- a. White
- b. Silver
- c. Black

Winder Finish

Plastic Winder Handle

- a. Black

Height Range

585mm to 885mm to underside of worktop

Travel

Winder (left or right position)

OR

Technician Adjustable (Winder frame with handle removed)

Travel Speed

2.5/mm per turn, 145 turns from 585mm to 885mm

Glide Adjustment

Plus or minus 5mm

Maximum inc. worktop 100kg
 Maximum Point Load 30kg
 Seats 2

E2-2000 2pax

H-Frame

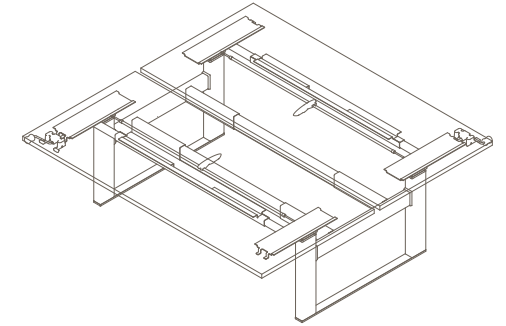
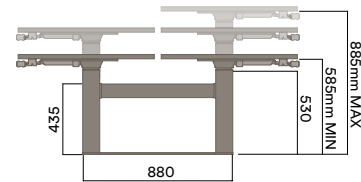
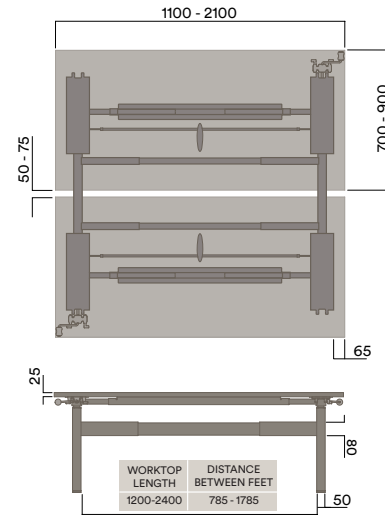

4 pax Configuration - 2x E2-2000

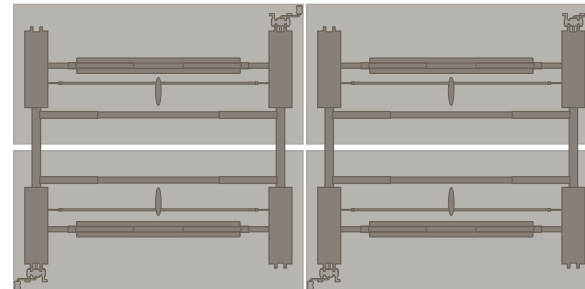

6 pax Configuration - 3x E2-2000

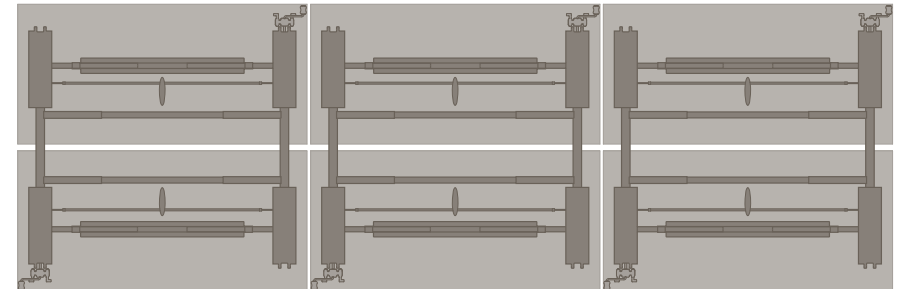

Manual Double Sided

Materials Information

Leg & Foot Finish

Powdercoat Steel Leg & Aluminium Foot

- a. White
- b. Silver
- c. Black

Frame Finish

Powdercoat Steel Frame

- a. White
- b. Silver
- c. Black

Winder Finish

Plastic Winder Handle

- a. Black

Height Range

585mm to 885mm to underside of worktop

Travel

Winder (left or right position)

OR

Technician Adjustable (Winder frame with handle removed)

Travel Speed

2.5/mm per turn, 145 turns from 585mm to 885mm

Glide Adjustment

Plus or minus 5mm

Maximum inc. worktop 100kg
 Maximum Point Load 30kg
 Seats 3 - 4

E2-3000 3pax

120deg H-Frame

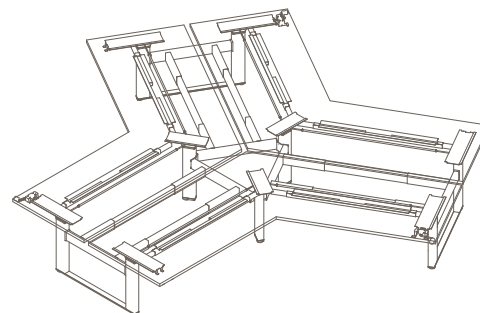
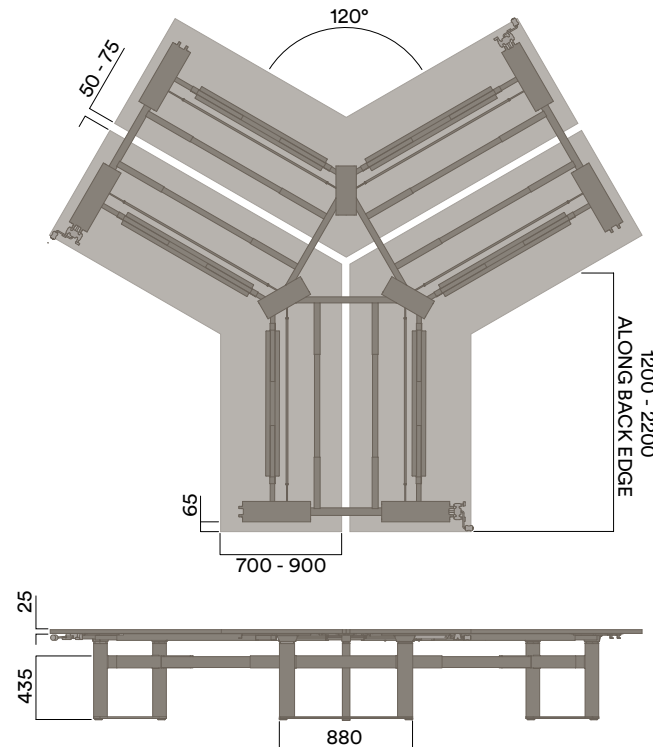

E2-4000 4pax

90deg H-Frame

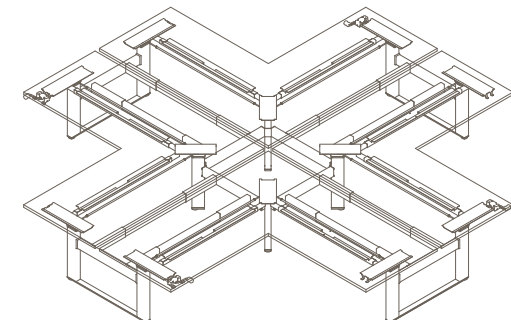
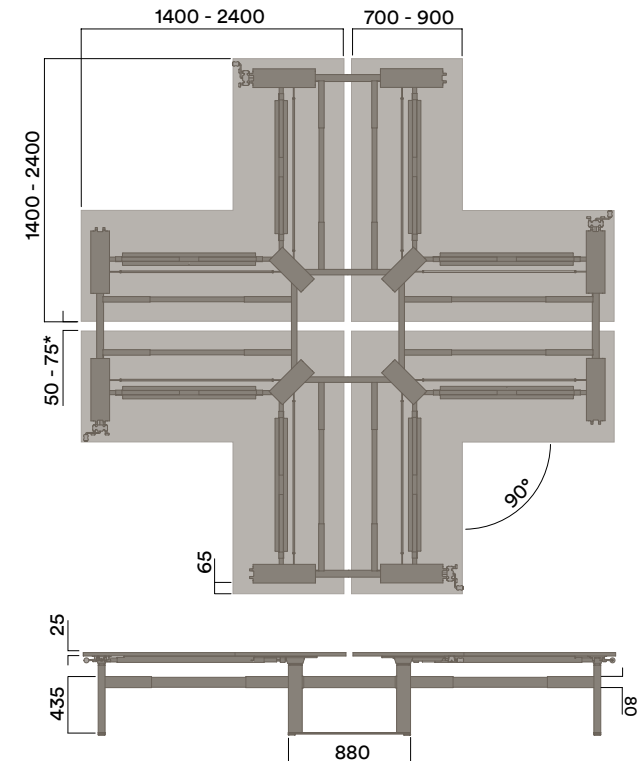

Accessories

Cable Management

Materials Information

Cable Basket

Wire Cable Basket

a. Black Powdercoat

Steel Segregation Gutter/Worktop Brackets

a. Black Powdercoat

Black Plastic Basket Hook

Cross Beam

Powdercoat Steel Cross Beam

a. White - to match frame

b. Silver - to match frame

c. Black - to match frame

E2-1100 Series

Mobile Single Sided Cable Basket

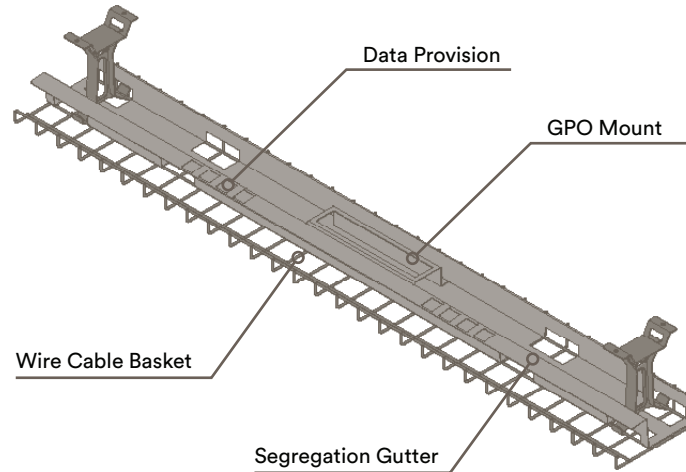

Worktop Mount Bracket

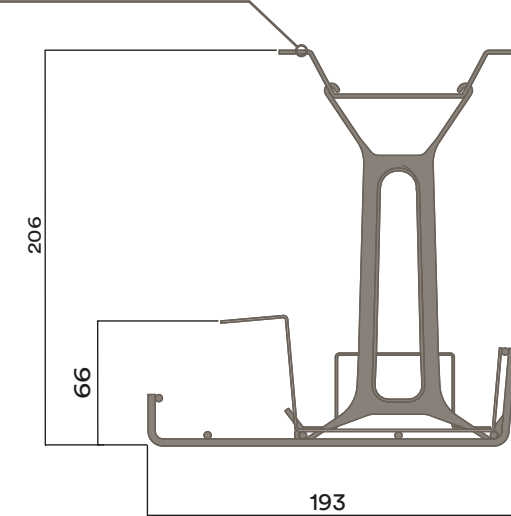

E2-1100 Series

Static Single Sided Cable Basket

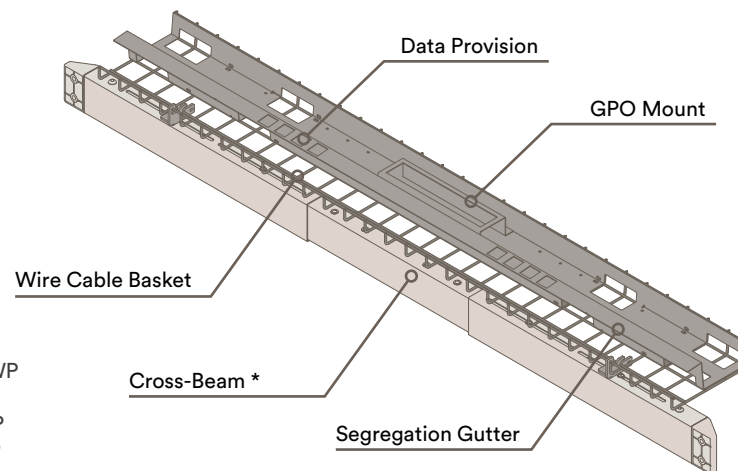

195

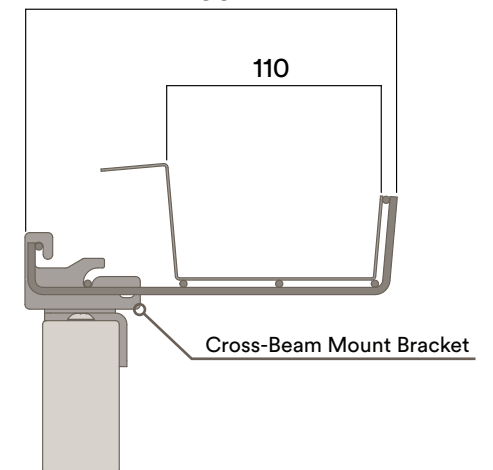

*Additional Frame Cross-Beam

Optional for Electric Single Sided 1200-2100mmWP

Optional for Electric 90/120deg 1400-1800mmWP

Required for Electric 90/120deg 1801-2100mmWP

Required for Static Cable Basket Configuration

Accessories

Cable Management

Materials Information

Cable Basket

Wire Cable Basket

a. Black Powdercoat

Steel Segregation Gutter/Worktop Brackets

a. Black Powdercoat

Black Plastic Basket Hook

Cable Umbilical

Black Plastic Umbilical

E2-2100 Series

Static Double Sided Cable Basket

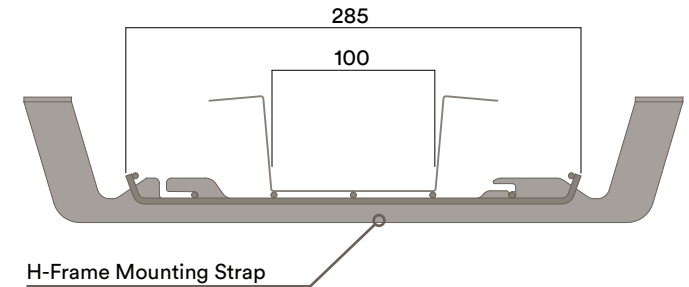
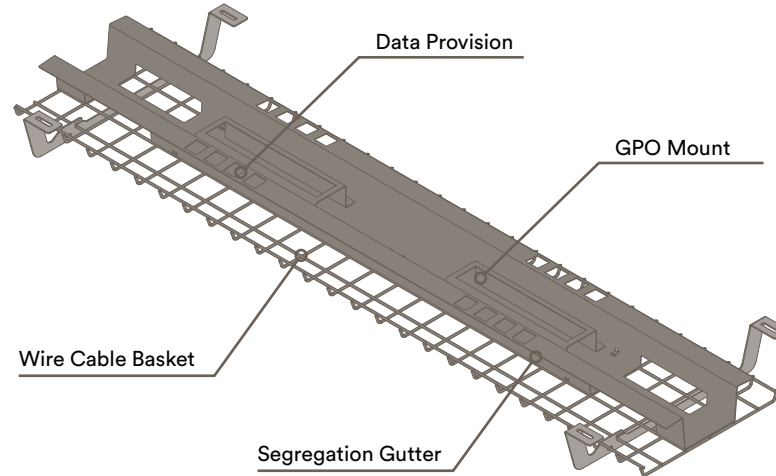

WSA-E-1120

900mm Cable Umbilical

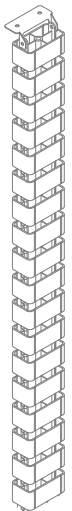
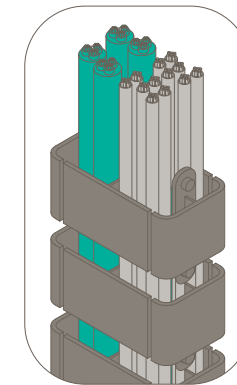
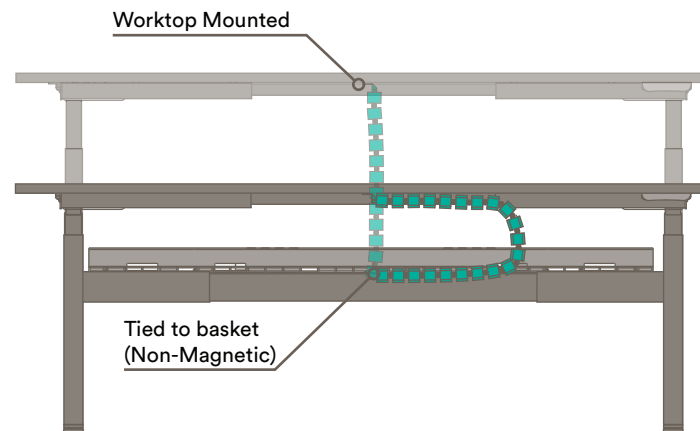

Umbilical Capacity
 4 × 12mm 20amp power cable
 12 × 6mm Cat 5 / Cat 6 data cable

Accessories

Generic Screen Brackets

Materials Information

Screen Bracket Kit

Powdercoat Steel Screen Brackets

- a. White - to match frame
- b. Silver - to match frame
- c. Black - to match frame

E2-6050 Series

1pax Single Sided Config.

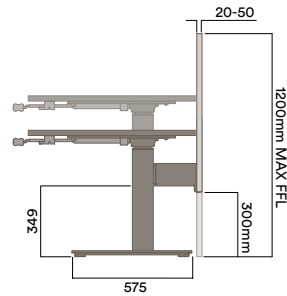
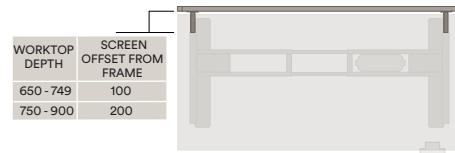

Screen Bracket Kits

1x Screen Config. - 1pax 90deg

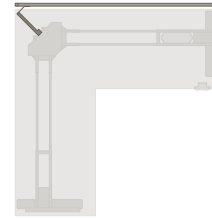

2x Screen Config. - 1pax 90deg

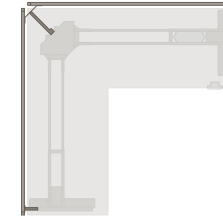

1x Screen Config. - 1pax 120deg

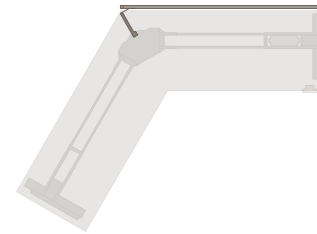

2x Screen Config. - 1pax 90deg

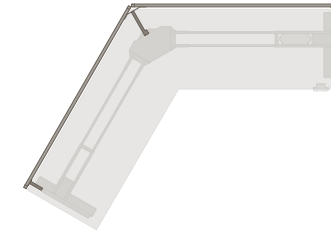

E2-6060

SCREEN LENGTH = WORKPOINT LENGTH + 30mm*



H-Frame Screen Brackets

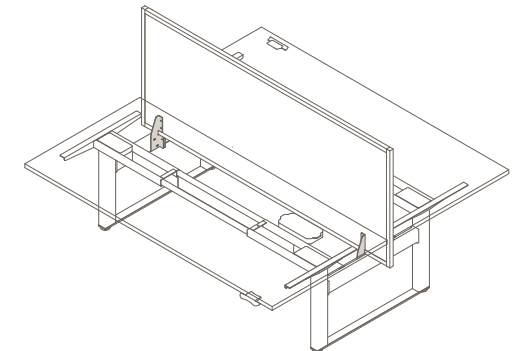
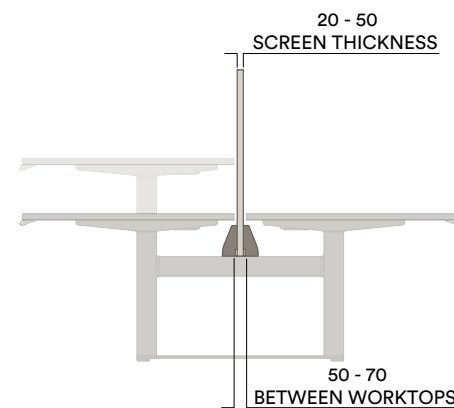

*30mm is minimum recommended spacing between worktops for adequate "finger gap"

Accessories

Wrap Screens

Materials Information

Wrap Screen

Wrap Screen Acoustic Panel

- a. Light Grey
- b. Dark Grey

Wrap Screen Rod & Bracket

Powdercoat Steel Screen Brackets

- a. Light Grey
- b. Dark Grey (to match Acoustic Panel)
- c. Other Colour

E2-6061

Single Sided Acoustic Screen

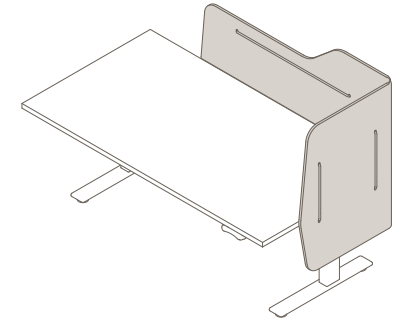
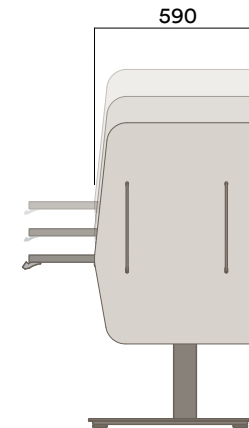
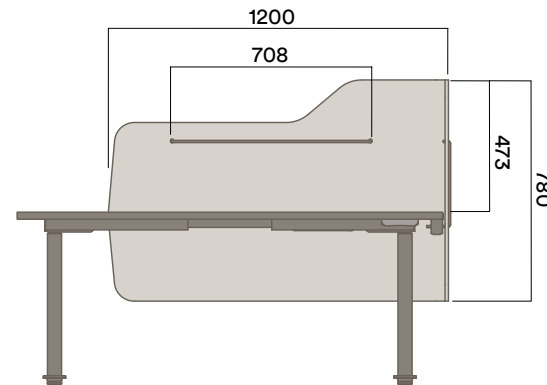

E2-6062

Back to Back Acoustic Screen

