

WORK WITH ME

Work Pods that screen you
from sight and sound.



**SWISS
DESIGN**
FURNITURE
MAKER
SINCE 1976



WORK WITH ME (WWM): WORK POD, WORK POD-C, CONFERENCE POD, MEETING POD AND LOUNGE POD

WORK WITH ME highlights the skill and craftsmanship of Australian made upholstery. Designed with a softer aesthetic and the ability to be customised, WORK WITH ME screens you from sight and sound. Fully upholstered furniture pods that shape your work place in a dynamic and efficient way.

WORK WITH ME utilizes a series of screens that combine to create a range of pods that allow individuals or teams (large or small) to retreat from the general open office environment for specific work modes.

WORK WITH ME is quick and easy to install and can be used with fixed work tops or freestanding height adjustable desks. There is also an option to reticulate power and data cables within the screens for seamless connectivity.



WORK POD

WORK POD-C



CONFERENCE POD

MEETING POD



LOUNGE POD



Allows you to create dynamic environments.

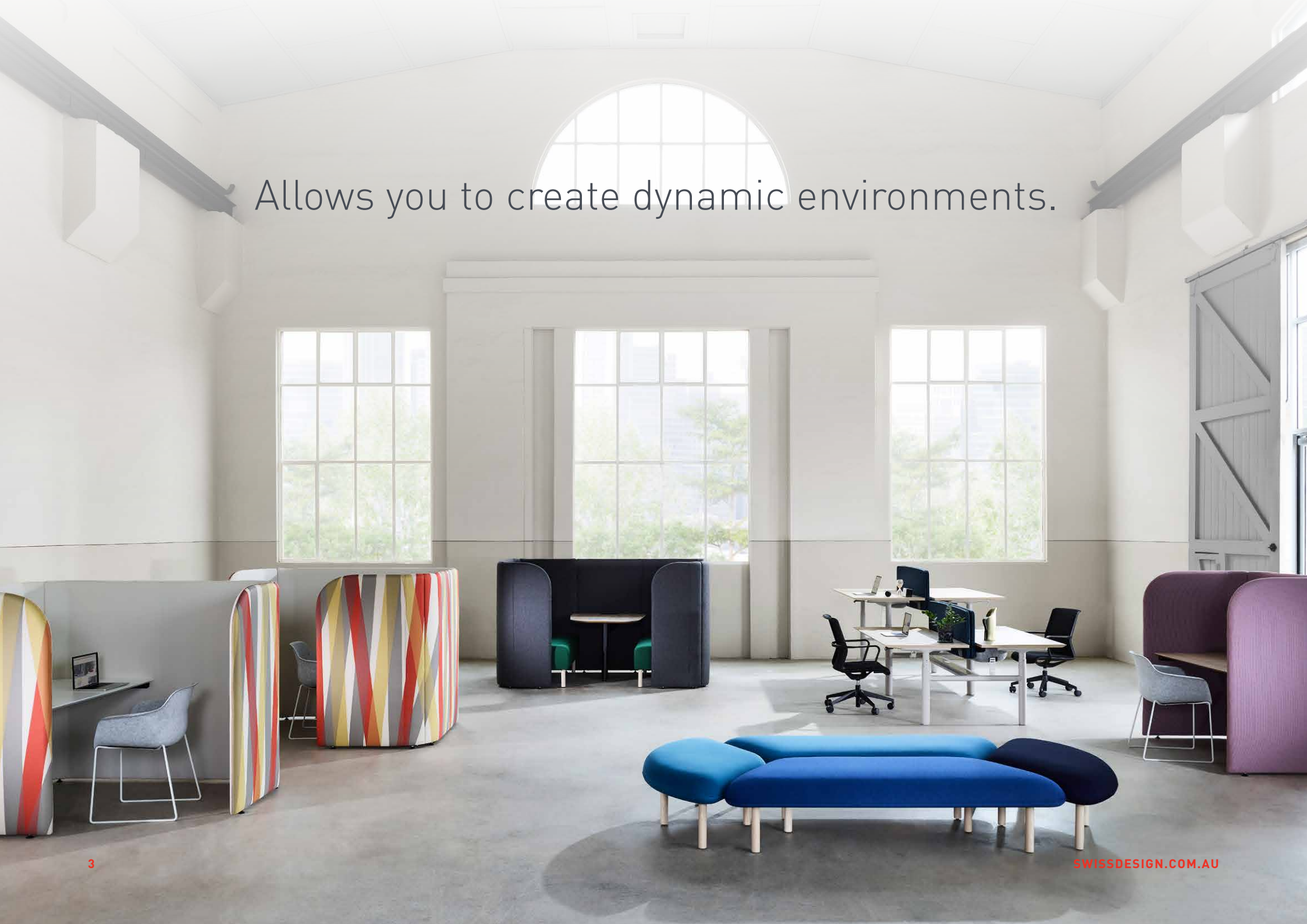

SUSTAINABLE DESIGN AND MANUFACTURE

Swiss Design products are created with a consideration for customization, time, and the environment. Water based glues, CFC free foams and sustainably sourced timbers are standard on every product produced in our factory. 100% Australian designed and manufactured.

FINISHES

WORK WITH ME is suited to a wide range of fabrics and leathers. The handcrafted upholstery is finished with a European cross stitch detail using automotive industry thread in matching or contrasting colours. This elegant detail celebrates the overall soft form of WORK WITH ME. Fully upholstered in approved contract fabrics and leathers.

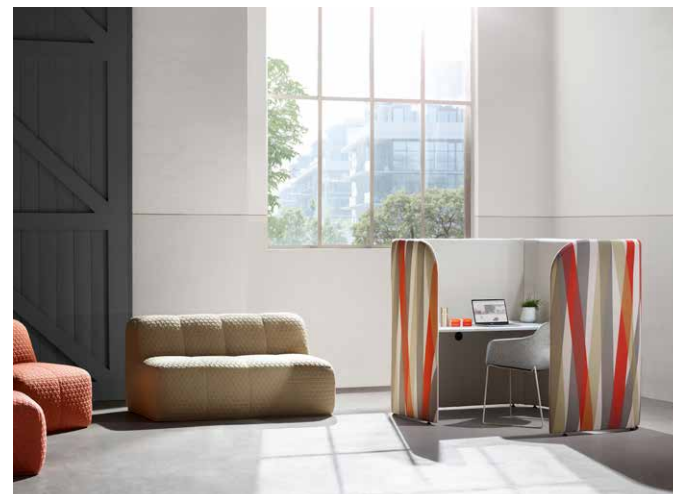

A close-up photograph of a green fabric, likely a textile or garment, featuring a prominent cross-stitch detail. The stitching is a vibrant green, creating a series of 'X' shapes along the edge of a lighter green fabric strip. The background is a dark, blurred gradient, emphasizing the texture and color of the fabric.

European cross stitch detail that celebrates the soft form with elegant detail and vibrant colours.

WORK POD

When you need to focus and concentrate on the task at hand, step into Work Pod, in three different size options. Screens with height adjustable glides are fully upholstered for optimum sound absorption and come in two heights. Cable reticulation within the screens come as standard. All screens are finished with a decorative stitch detail or twin needle stitch detail. Work Pod can be fitted with a fixed height work top at three optional heights, at 800mm deep, or a freestanding height adjustable desk.

WORK POD-C

This compact work pod is a space saver and suitable for the more transient worker, never staying too long but needing a place to touch-down for a few hours. Screens with height adjustable glides are fully upholstered for optimum sound absorption and come in two heights. Cable reticulation within the screens come as standard. All screens are finished with a decorative stitch detail or twin needle stitch detail. Work Pod-C can be fitted with a fixed height work top at three optional heights, at 800mm deep, or a freestanding height adjustable desk.

FEATURES

- Three Sizes: 1200, 1400, 1800
- Two Heights: 1400, 1800
- Screens with standard cable reticulation
- Height adjustable glides
- Fixed work top at three optional heights: 720, 900, 1050
- Decorative or Twin Needle stitch detail
- Two-tone upholstery
- Optional contrasting decorative stitch



WORK POD



WORK POD-C

Quick and easy to install and can be used with a fixed work top or freestanding height adjustable desk.



A space saver for the more transient worker
needing a place to touch-down.



Daisy-chain your Work Pod-C and save.



CABLE RETICULATION

WORK WITH ME has been designed to reticulate power and data cables hidden within the screen panel.

Cable access through the highlighted screen panel from floor to table level is standard on both Work Pods and Booths.



Designed to utilise the C series cables from CMS Electracom.

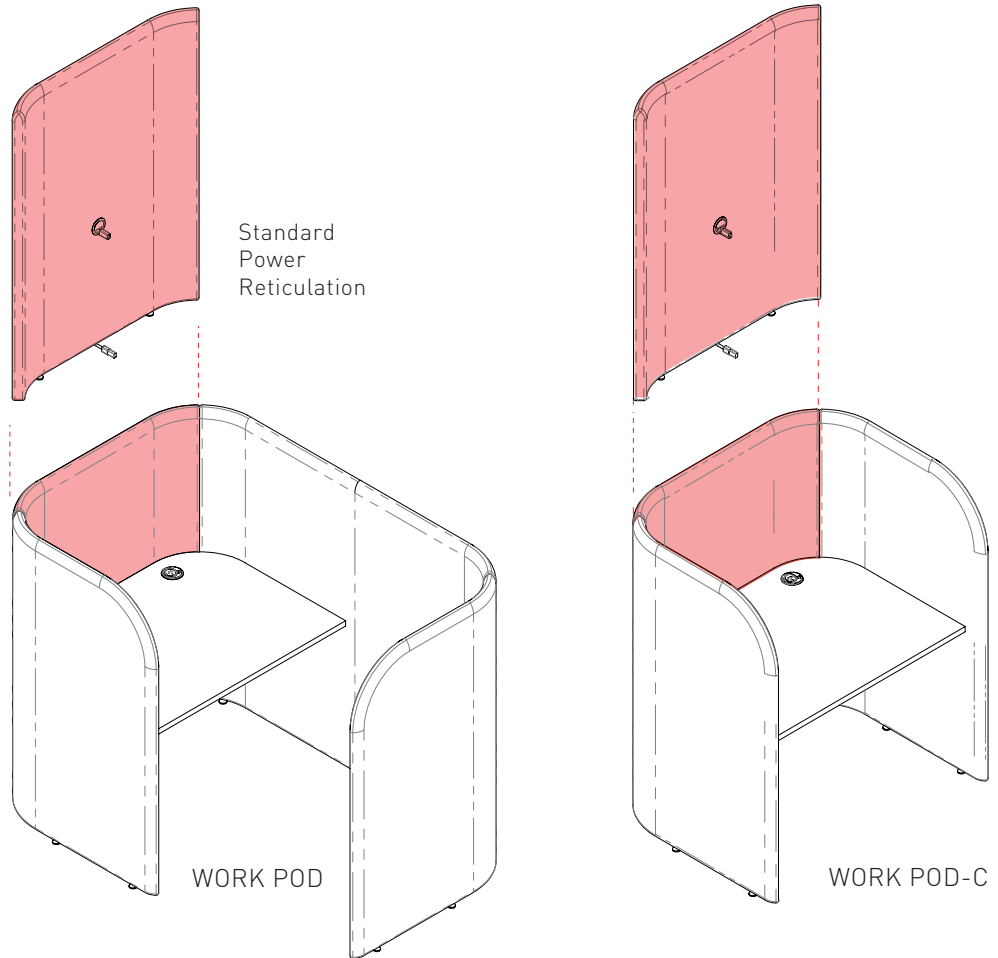

WORK POD-C DIMENSIONS

Available in two Heights

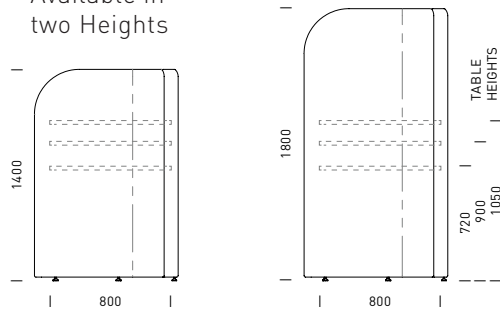

WP-C1200

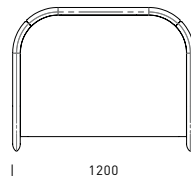

WP-C1400

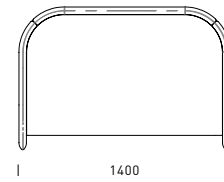

WP-C1800

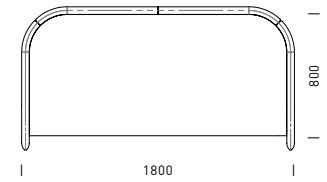

WORK POD DIMENSIONS

Available in two Heights

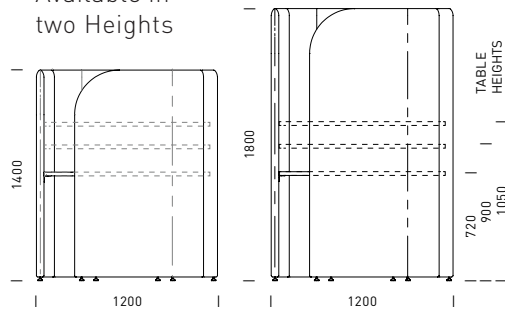

WP1200L (LHS)

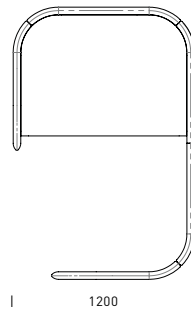

WP1400L (LHS)

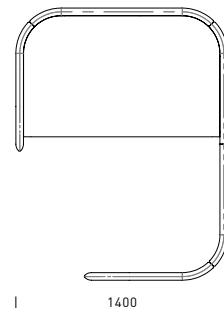

WP1800L (LHS)

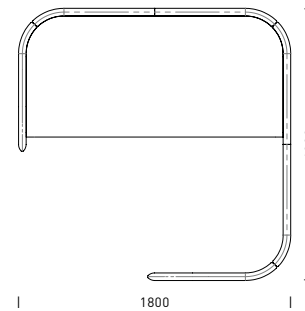

WORK POD is available in Left and Right Hand Side configurations

WORK POD-C DAISY CHAIN CONFIGURATIONS

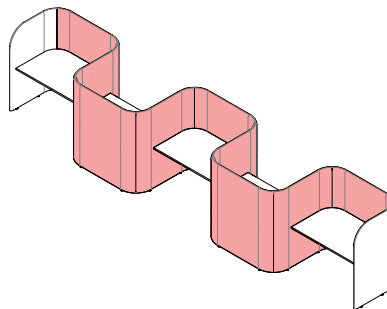
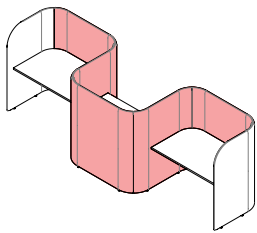
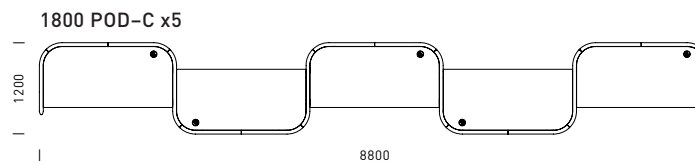
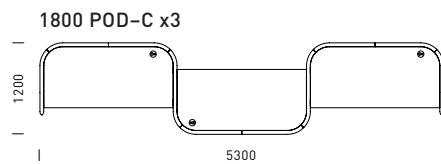
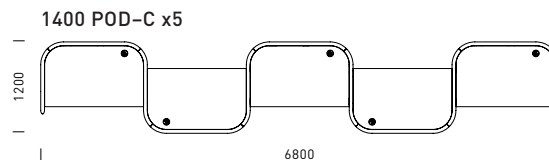
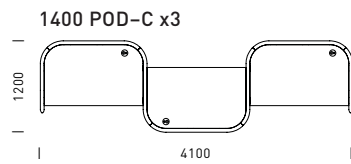
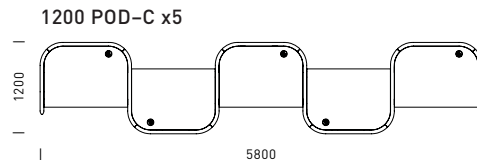
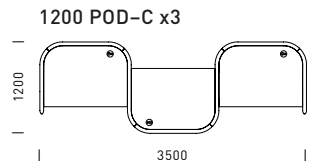

CONFERENCE POD

The perfect alternative to building a conference room. As well as a meeting pod you can use it in multiple ways. Furnish it with comfy soft seating and use as a hub to retreat in or cafe style tables as a lunch room. Screens with height adjustable glides are fully upholstered for optimum sound absorption at 1800mm high, in three generous sizes and is completely freestanding. Support rails fixed to three sides provide stability. When a meeting table top is fixed to a screen, the support rail for that side is no longer required. The support rails also function as a narrow ledge/shelf and provides options for power and data outlets. Additional power and data cable can be fitted for connection to screen mounted AV. Standard cable reticulation from floor into selected screens.

FEATURES

- Three Sizes - 2400x2400, 2800x2800, 3600x3600
- One Height - 1800
- Selected screens with standard cable reticulation
- Height adjustable glides
- Decorative or Twin Needle stitch detail
- Two-tone upholstery
- Optional contrasting decorative stitch
- Support Rails to three sides
- Cable & data connection to AV monitor
- Optional screen mounted AV



The perfect alternative to
building a conference room.



Collaborative
teamwork.



CONFERENCE POD DIMENSIONS

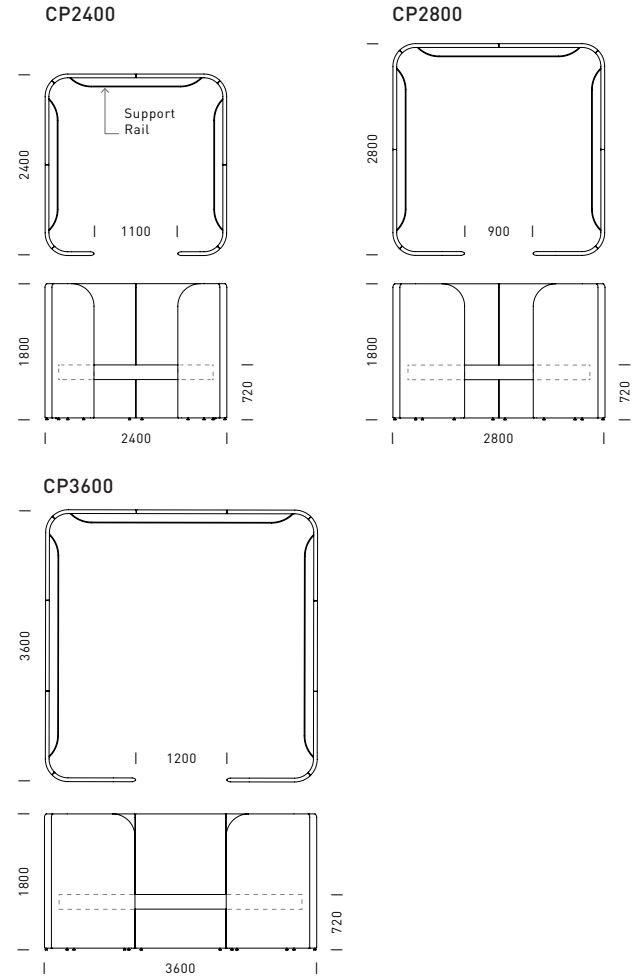

CONFERENCE POD CABLE RETICULATION

Cable access through the highlighted screen panels from floor to table level is standard.

Note: Support rails are required on three sides. When meeting table top is fixed to a side, the support rail on that side is no longer required. The support rail can be fitted with the CMS Electracom's in desk dual GPO/USB Flipbox. WORK WITH ME has been designed to reticulate power and data cables hidden within the screen panel. Designed to utilize the C Series cables form CMS Electracom.

CONFERENCE POD AV (OPTIONAL)

The Audio Visual option for the Conference Pod includes dual cable access from floor to table to monitor level through the screen. Option also includes CMS Electracom's in wall TV mount.

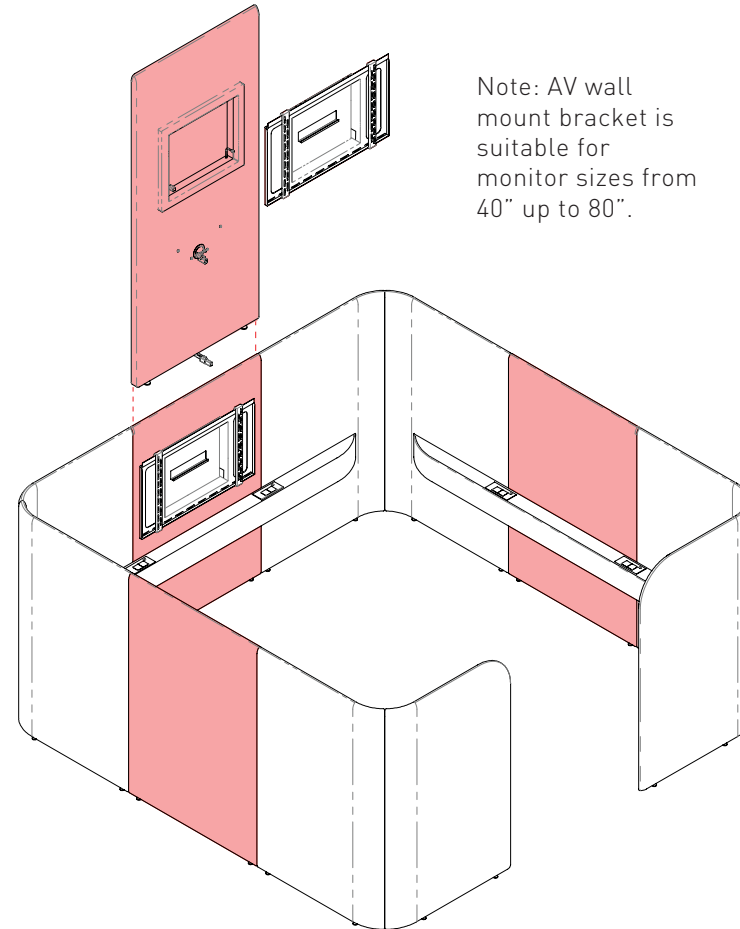

MEETING POD

For small meetings Meeting Pod comes in multiple sizes to suit two, four and six persons who wish to gather, share and engage. Meeting Pods includes upholstered lounges on timber legs to suit meeting table height. Screens with height adjustable glides are fully upholstered for optimum sound absorption and come in two heights. Cable reticulation within the screens come as standard. All screens are finished with a decorative stitch detail or twin needle stitch detail. An option for screen mounted AV on the 1800mm high screen only.

FEATURES

- Three Sizes: 1200, 1400, 1800
- Two Heights: 1400, 1800
- Screens with standard cable reticulation
- Height adjustable glides
- Two-tone upholstery
- Optional contrasting decorative stitch
- Upholstered lounge seat on timber legs, fixed to screen
- Meeting Table top as specified and powder coated support leg.



Gather, share and engage.



CABLE RETICULATION

Cable access from floor to table level through the screen is standard on this product.

Note: Table and GPO are NOT included. Table bracket has been designed to suit CMS Electracom's in desk dual GPO/USB Flipbox. Use of any other GPO must be confirmed with the factory prior to placing order. Only use CMS Electracom "C" series power cables.

MEETING POD AV (OPTIONAL)

The Audio Visual option for the Meeting Pod includes dual cable access from floor to table to monitor level through the screen. Option also includes CMS Electracom's in wall TV mount.

Note: Table and GPO are NOT included. Table bracket has been designed to suit CMS Electracom's in desk dual GPO/USB Flipbox. Use of any other GPO must be confirmed with the factory prior to placing order. Only use CMS Electracom "C" series power cables.

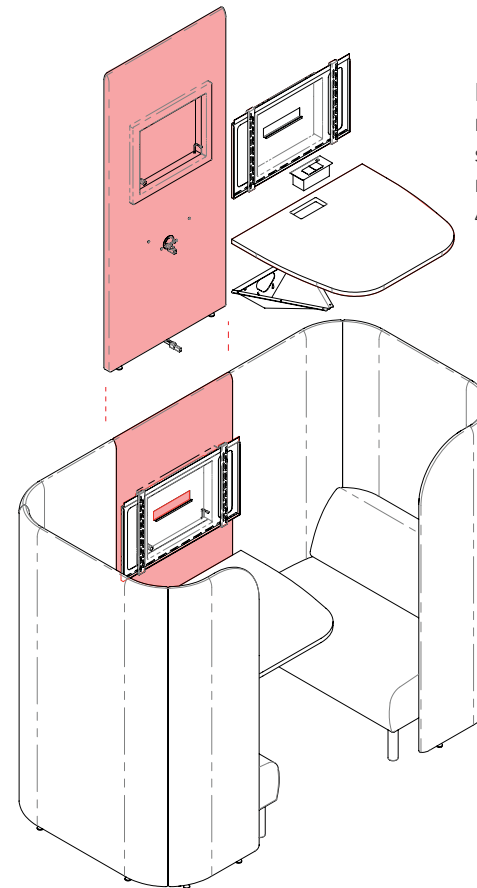

Note: AV wall mount bracket is suitable for monitor sizes from 40" up to 80".

MEETING POD DIMENSIONS

MP1200
[Table leg not required]

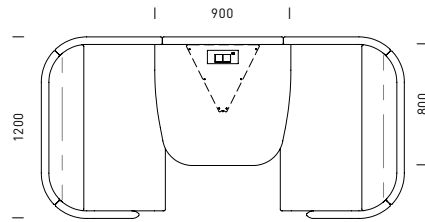

MP1400

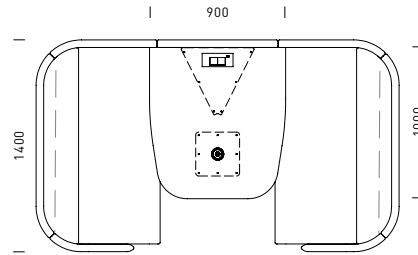

MP1800

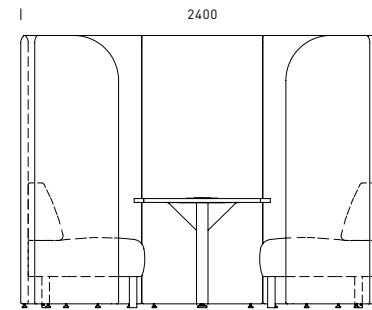
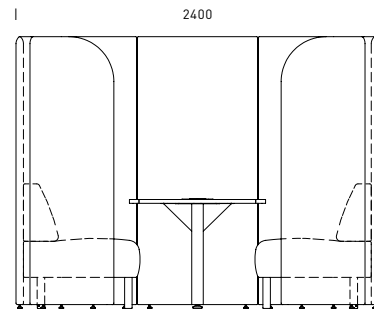
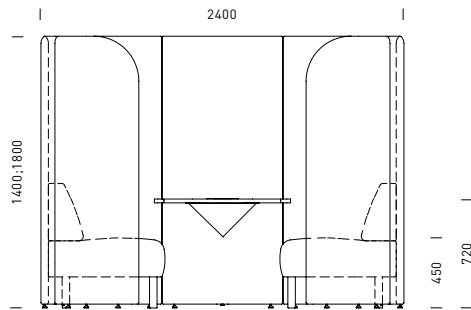
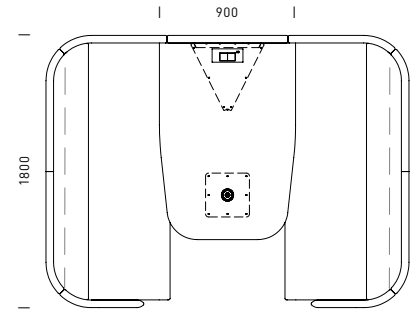

LOUNGE POD

Provides a private space for a phone call or one on one discussion. Alternatively, multiple lounge pods could be used to create a more versatile meeting hub. For varying levels of privacy the Lounge Pod comes in two heights. In keeping with the welcoming soft aesthetic the lounge seat is available with solid timber legs in a variety of finishes.

FEATURES

- Three Sizes: 1200, 1400, 1800
- Two Heights: 1400, 1800
- Height adjustable glides
- Decorative or twin needle stitch detail
- Two-tone upholstery
- Optional contrasting decorative stitch
- Freestanding upholstered lounge seat on solid timber legs, fixed to screen
- Various solid timber leg finishes



Private space for a
phone call or one on
one discussion.



LOUNGE POD DIMENSIONS

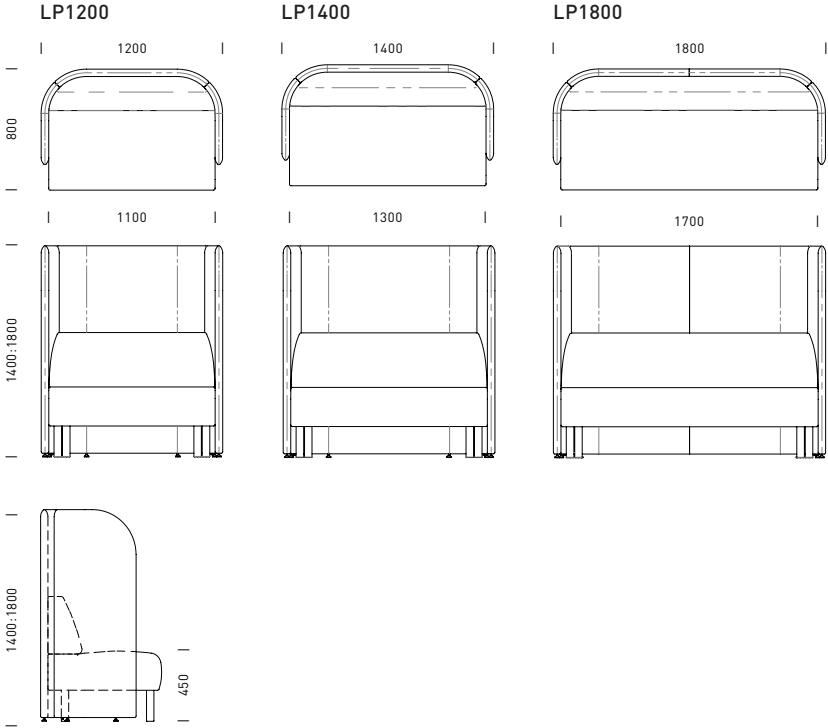

LOUNGE

A freestanding lounge for open areas or enclosed offices in various sizes, encourages continuity of style and presence in a professional work environment.

FEATURES

- Three Sizes: 1100, 1300, 1700
- Decorative or twin needle stitch details
- Two-tone upholstery
- Optional contrasting decorative stitch
- Solid Ash timber leg clear or Black Japan finish as standard

LOUNGE DIMENSIONS

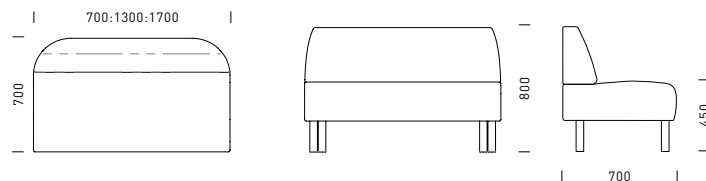



Decorative stitch detail or
twin needle stitch detail.

CARE & MAINTENANCE

FABRIC

- Upholstered products such as lounges should be protected from direct sunlight as this may lighten fabric colour
- Vacuum regularly on low suction
- Regularly rotate reversible cushions to allow even fading

LEATHER

- Upholstered products such as lounges should be protected from direct sunlight, direct heat and weather
- Regularly dust with a clean dry duster

POWDER COATED & CHROME STEEL

- Chair and table legs should be wiped down with a soft damp cloth
- Do not use abrasive cleaning products

LAMINATE

- Desks & tables should be cleaned with a soft, damp cloth
- Do not use abrasive cleaning products
- Wipe any liquid spills away quickly



**SWISS
DESIGN**
FURNITURE
MAKER
SINCE 1976