

Colours Seating System Specification Guide

Colours is a modular seating product comprised of 12 unique modules which may be used interchangeably to create an unlimited number of configurations. To select the modules that are appropriate for your application use the guide below.

Colours is fully upholstered with saddle stitch detailing. Fabric and vinyl applications will be railroaded. Leather will incorporate saddle stitch seams on the top panel. When submitting COM, please provide a continuous roll of fabric in the total yardage for the configuration(s). Non-marring glides with vinyl sleeves prevent the units from sliding on smooth surfaces. GREENGUARD certified.

Due to the organic shapes, the dimensions can vary depending on the orientation of the product. Therefore, a maximum dimension is provided in the price list information. The 2D models provide dimensioned drawings of Colours. Consult BernhardtDesign.com for a complete library of 2D, 3D and Revit models.

Contact your local sales representative or the Bernhardt Design corporate office for specification assistance.

Connecting Modules

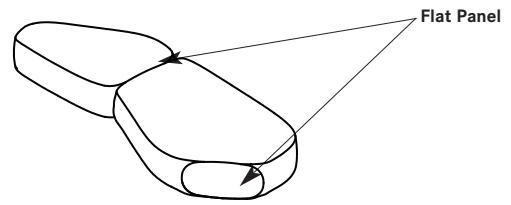

Non-Connecting Modules

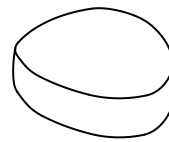

Non-Connecting Modules

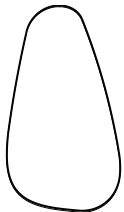

Colours 1
4831

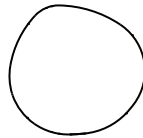

Colours 2
4832

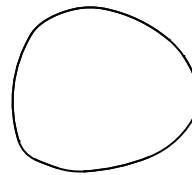

Colours 3
4833

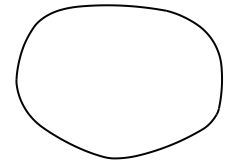

Colours 4
4834

Connecting Modules

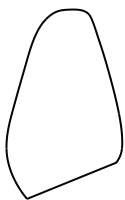

Colours 5
4835



Colours 6
4836

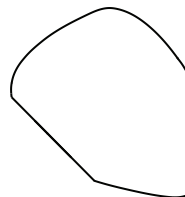

Colours 7
4837

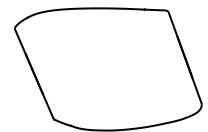

Colours 8
4838

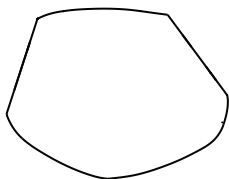

Colours 9
4839

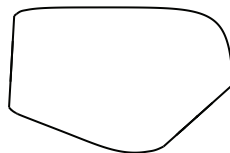

Colours 10
4840

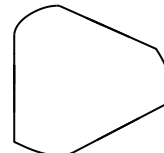

Colours 11
4841

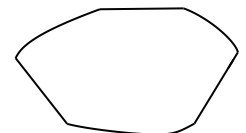

Colours 12
4842

Colours - Fabric and Leather Alternative Application

Fabric and leather alternative covers incorporate seamless top panels. Fabric will be Railroaded on the top panel for all skus. Striped or plaid fabrics and certain patterns with distinct direction are not suitable for application. Solids, textures and leathers are recommended.

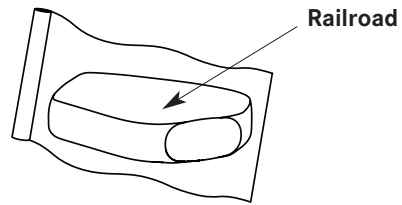
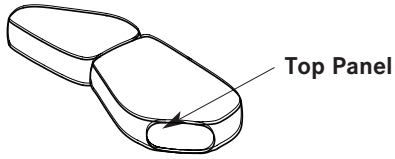

Colours - Leather Application

Leather covers incorporate saddle stitch seams on the top panel. See diagrams below, noting seam locations for each sku.

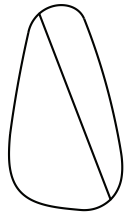
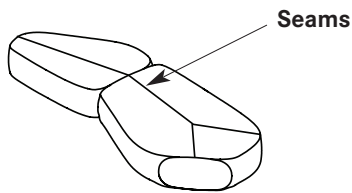

Colours 1
4831

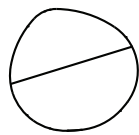

Colours 2
4832

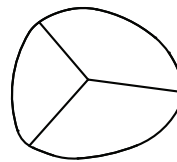

Colours 3
4833

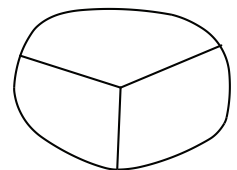

Colours 4
4834

Connecting Modules

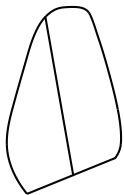

Colours 5
4835



Colours 6
4836

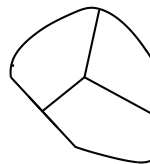

Colours 7
4837

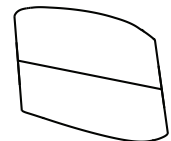

Colours 8
4838

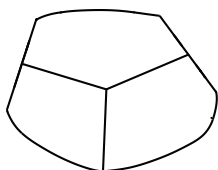

Colours 9
4839

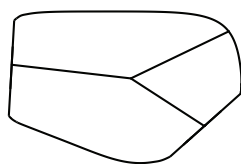

Colours 10
4840

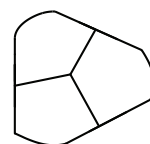

Colours 11
4841

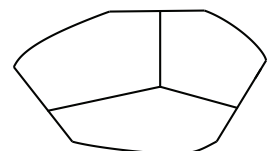

Colours 12
4842

Description

1

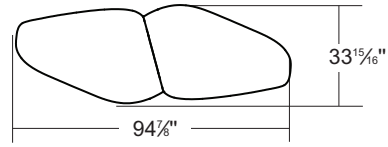
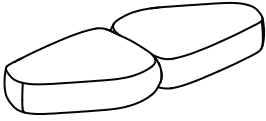

4835 Colours 5
4835 Colours 5

2

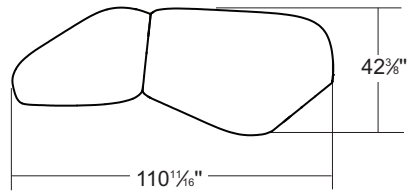
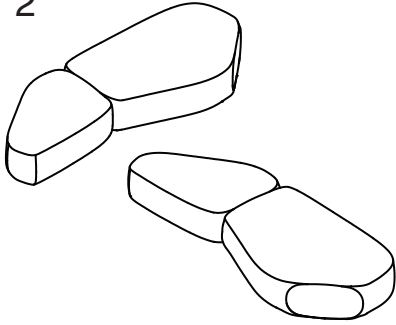

4836 Colours 6
4840 Colours 10

3

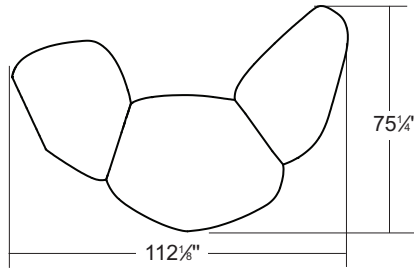
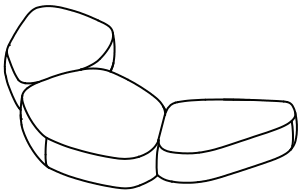

4837 Colours 7
4839 Colours 9
4836 Colours 6

4

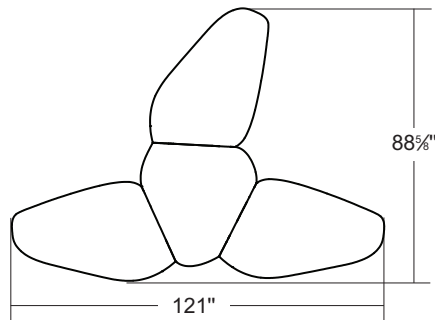
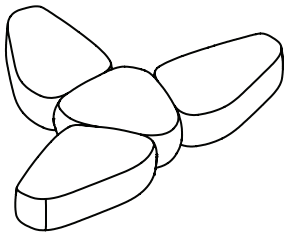

4835 Colours 5
4841 Colours 11
4835 Colours 5
4836 Colours 6

5

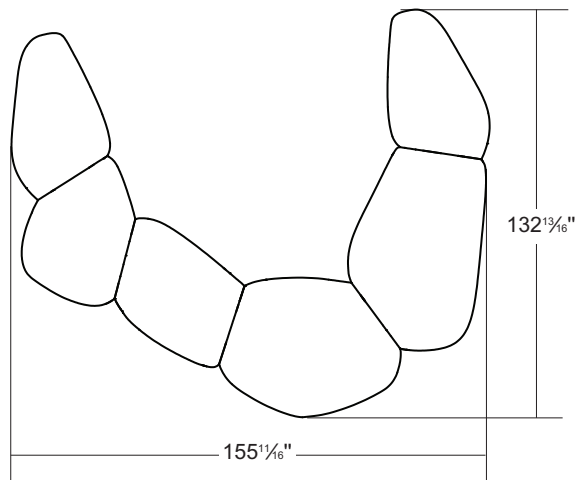
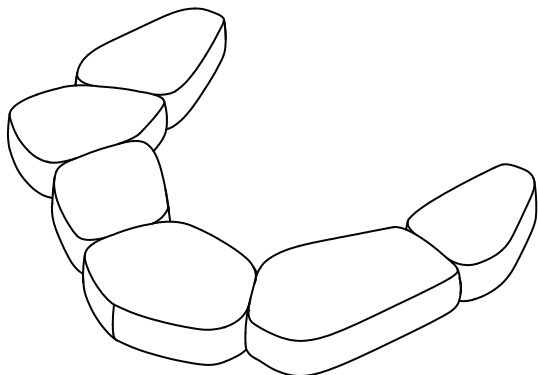

4835 Colours 5
4837 Colours 7
4838 Colours 8
4839 Colours 9
4840 Colours 10
4836 Colours 6

Description

6

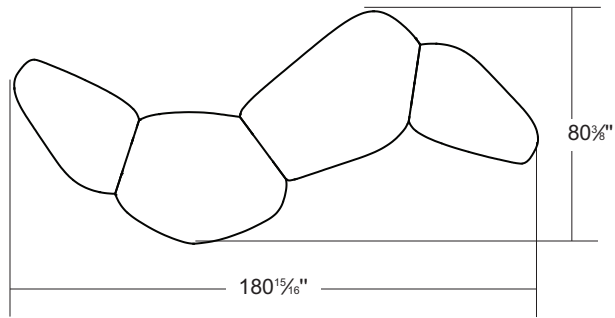
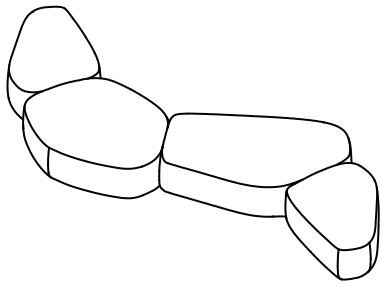

4835 Colours 5
4839 Colours 9
4840 Colours 10
4835 Colours 5

7

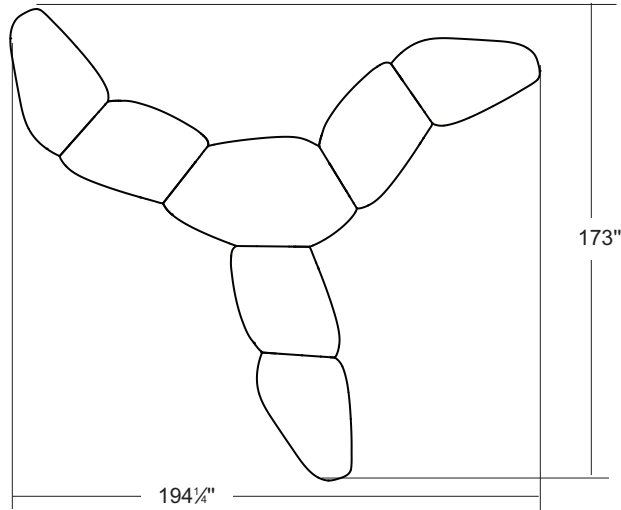
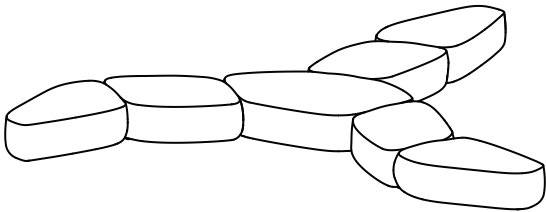

4835 Colours 5
4838 Colours 8
4842 Colours 12
4838 Colours 8
4835 Colours 5

4838 Colours 8
4836 Colours 6

8

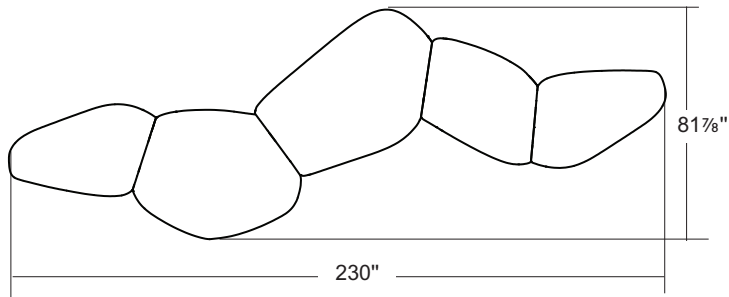
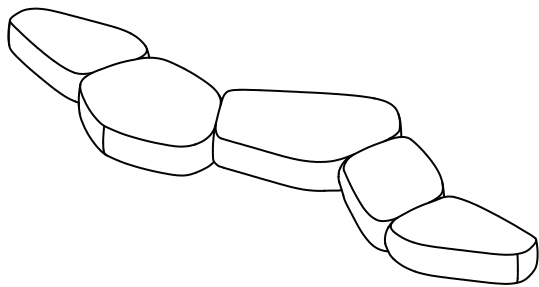

4836 Colours 6
4839 Colours 9
4840 Colours 10
4838 Colours 8
4836 Colours 6

9

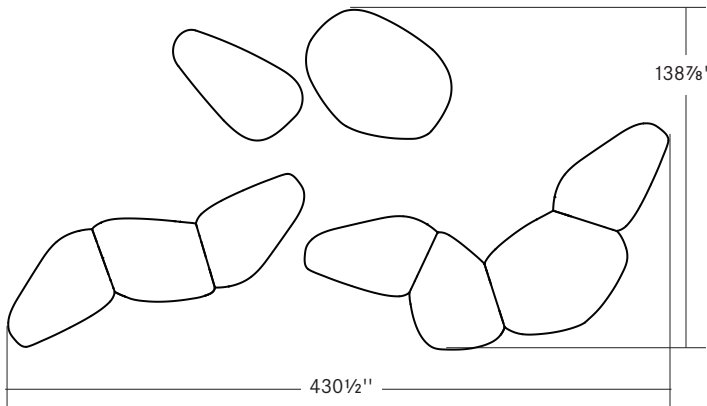
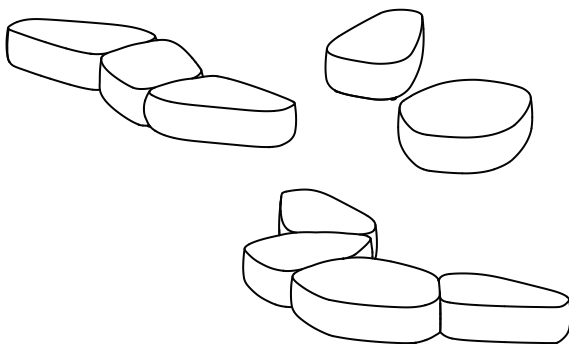

4831 Colours 1
4834 Colours 4
4836 Colours 6
4838 Colours 8
4836 Colours 6

4836 Colours 6
4837 Colours 7
4839 Colours 9
4835 Colours 5

	Seat Height	Max Dim.	W	D	H	Fabric	Leather	Weight	Cubes/Qty
colours 1 4831	16½"	59¼"	33½"	59¼"	16½"	5.5 yds.	85.0'	70 lbs.	68.33' / 1
	419 mm	1505 mm	851 mm	1505 mm	419 mm	5.0 m	7.9 sqm	31.8 kg	1.93 cu.

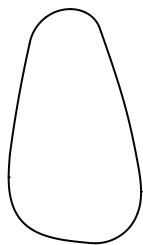

Level I and GREENGUARD Certified

Non-connecting module. Freestanding only. Fully upholstered with saddle stitch detail. Fabric **Railroaded**. Leather has seamed top. When submitting COM, please provide a continuous roll of fabric in the total yardage for the configuration(s). Striped or plaid fabrics and certain patterns with distinct direction are not suitable for application. Solids, textures and leathers are recommended. *All **COM/COL** fabrics must be preapproved by Bernhardt Design prior to application.

When using a combination of fabrics or leathers, the following yardage must be used and upcharges apply. See terms and conditions for contrasting fabric upcharges.

- A) One fabric or leather for top panel
yardage: 2.5 yds. leather: 40.0 sq. ft.
- B) One fabric or leather for body
yardage: 3.0 yds. leather: 50.0 sq. ft.

Please specify the fabric or leather application by designating the appropriate letter on the purchase order.

colours 2 4832	16½"	32¾"	32¾"	31⅝"	16½"	3.5 yds.	57.0'	40 lbs.	16.39' / 1
	419 mm	835 mm	835 mm	803 mm	419 mm	3.2 m	5.3 sqm	18.2 kg	.46 cu.

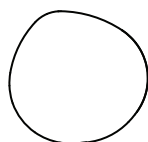

Level I and GREENGUARD Certified

Non-connecting module. Freestanding only. Fully upholstered with saddle stitch detail. Fabric **Railroaded**. Leather has seamed top. When submitting COM, please provide a continuous roll of fabric in the total yardage for the configuration(s). Striped or plaid fabrics and certain patterns with distinct direction are not suitable for application. Solids, textures and leathers are recommended. *All **COM/COL** fabrics must be preapproved by Bernhardt Design prior to application.

When using a combination of fabrics or leathers, the following yardage must be used and upcharges apply. See terms and conditions for contrasting fabric.

- A) One fabric or leather for top panel
yardage: 1.5 yds. leather: 25.0 sq. ft.
- B) One fabric or leather for body
yardage: 2.0 yds. leather: 32.0 sq. ft.

Please specify the fabric or leather application by designating the appropriate letter on the purchase order.

colours 3 4833	16½"	43¾"	43¾"	38¾"	16½"	5.25 yds.	90.0'	66 lbs.	30.47' / 1
	419 mm	1111 mm	1111 mm	975 mm	419 mm	4.8 m	8.4 sqm	30.0 kg	.86 cu.

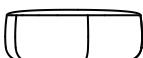
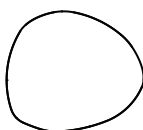

Level I and GREENGUARD Certified

Non-connecting module. Freestanding only. Fully upholstered with saddle stitch detail. Fabric **Railroaded**. Leather has seamed top. When submitting COM, please provide a continuous roll of fabric in the total yardage for the configuration(s). Striped or plaid fabrics and certain patterns with distinct direction are not suitable for application. Solids, textures and leathers are recommended. *All **COM/COL** fabrics must be preapproved by Bernhardt Design prior to application.

When using a combination of fabrics or leathers, the following yardage must be used and upcharges apply. See terms and conditions for contrasting fabric.

- A) One fabric or leather for top panel
yardage: 2.0 yds. leather: 32.0 sq. ft.
- B) One fabric or leather for body
yardage: 3.6 yds. leather: 65.0 sq. ft.

Please specify the fabric or leather application by designating the appropriate letter on the purchase order.

	Seat Height	Max Dim.	W	D	H	Fabric	Leather	Weight	Cubes/Qty
colours 4 4834	16½"	61½"	61½"	45¾"	16½"	4.1 yds.	70.0'	80 lbs.	80.67' / 1
	419 mm	1562 mm	1562 mm	1165 mm	419 mm	3.7 m	6.5 sqm	36.4 kg	2.28 cu.

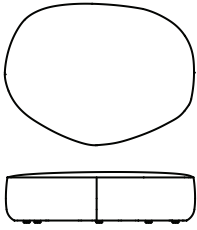

Level I and GREENGUARD Certified

Non-connecting module. Freestanding only. Fully upholstered with saddle stitch detail. Fabric **Railroaded**. Leather has seamed top. When submitting COM, please provide a continuous roll of fabric in the total yardage for the configuration(s). Striped or plaid fabrics and certain patterns with distinct direction are not suitable for application. Solids, textures and leathers are recommended. *All **COM/COL** fabrics must be preapproved by Bernhardt Design prior to application.

When using a combination of fabrics or leathers, the following yardage must be used and upcharges apply. See terms and conditions for contrasting fabric.

- A) One fabric or leather for top panel
yardage: 1.75 yds. leather: 30.0 sq. ft.
- B) One fabric or leather for body
yardage: 2.65 yds. leather: 40.0 sq. ft.

Please specify the fabric or leather application by designating the appropriate letter on the purchase order.

colours 5 4835	16½"	52¾"	33"	52¾"	16½"	2.5 yds.	43.0'	51 lbs.	23.14' / 1
	419 mm	1340 mm	838 mm	1340 mm	419 mm	2.3 mm	4.0 sqm	23.2 kg	.66 cu.

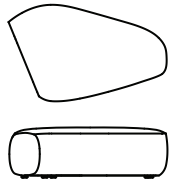

Level I and GREENGUARD Certified

Connecting module. Fully upholstered with saddle stitch detail. Fabric **Railroaded**. Leather has seamed top. When submitting COM, please provide a continuous roll of fabric in the total yardage for the configuration(s). Striped or plaid fabrics and certain patterns with distinct direction are not suitable for application. Solids, textures and leathers are recommended. *All **COM/COL** fabrics must be preapproved by Bernhardt Design prior to application.

When using a combination of fabrics or leathers, the following yardage must be used and upcharges apply. See terms and conditions for contrasting fabric.

- A) One fabric or leather for top panel
yardage: 1.25 yds. leather: 20.25 sq. ft.
- B) One fabric or leather for body
yardage: 1.6 yds. leather: 25.0 sq. ft.

Please specify the fabric or leather application by designating the appropriate letter on the purchase order.

colours 6 4836	16½"	52¾"	33"	52¾"	16½"	3.5 yds.	56.7'	51 lbs.	23.14' / 1
	419 mm	1340 mm	838 mm	1340 mm	419 mm	3.2 m	5.3 sqm	23.2 kg	.66 cu.

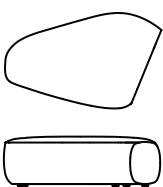

Level I and GREENGUARD Certified

Connecting module. Fully upholstered with saddle stitch detail. Fabric **Railroaded**. Leather has seamed top. When submitting COM, please provide a continuous roll of fabric in the total yardage for the configuration(s). Striped or plaid fabrics and certain patterns with distinct direction are not suitable for application. Solids, textures and leathers are recommended. *All **COM/COL** fabrics must be preapproved by Bernhardt Design prior to application.

When using a combination of fabrics or leathers, the following yardage must be used and upcharges apply. See terms and conditions for contrasting fabric.

- A) One fabric or leather for top panel
yardage: 1.55 yds. leather: 30.0 sq. ft.
- B) One fabric or leather for body
yardage: 2.1 yds. leather: 34.0 sq. ft.

Please specify the fabric or leather application by designating the appropriate letter on the purchase order.

	Seat Height	Max Dim.	W	D	h	Fabric	Leather	Weight	Cubes/Qty
colours 7 4837	16½"	48¾"	48¾"	33¾"	16½"	5.75 yds.	95.0'	73 lbs.	39.14' / 1
	419 mm	1241 mm	1241 mm	857 mm	419 mm	5.3 m	8.8 sqm	33.2 kg	1.10 cu.

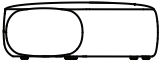
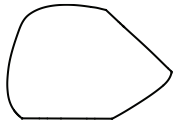

Level I and GREENGUARD Certified

Connecting module. Fully upholstered with saddle stitch detail. Fabric **Railroaded**. Leather has seamed top. When submitting COM, please provide a continuous roll of fabric in the total yardage for the configuration(s). Striped or plaid fabrics and certain patterns with distinct direction are not suitable for application. Solids, textures and leathers are recommended. *All **COM/COL** fabrics must be preapproved by Bernhardt Design prior to application.

When using a combination of fabrics or leathers, the following yardage must be used and upcharges apply. See terms and conditions for contrasting fabric.

- A) One fabric or leather for top panel
yardage: 2.0 yds. leather: 35.0 sq. ft.
- B) One fabric or leather for body
yardage: 3.75 yds. leather: 60.0 sq. ft.

Please specify the fabric or leather application by designating the appropriate letter on the purchase order.

colours 8 4838	16½"	54⅝"	50⅝"	33"	16½"	3.6 yds.	65.0'	51 lbs.	23.14' / 1
	419 mm	1387 mm	1280 mm	838 mm	419 mm	3.3 m	6.0 sqm	23.2 kg	.66 cu.

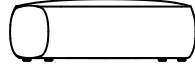
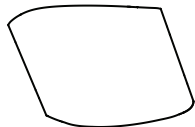

Level I and GREENGUARD Certified

Connecting module. Fully upholstered with saddle stitch detail. Fabric **Railroaded**. Leather has seamed top. When submitting COM, please provide a continuous roll of fabric in the total yardage for the configuration(s). Striped or plaid fabrics and certain patterns with distinct direction are not suitable for application. Solids, textures and leathers are recommended. *All **COM/COL** fabrics must be preapproved by Bernhardt Design prior to application.

When using a combination of fabrics or leathers, the following yardage must be used and upcharges apply. See terms and conditions for contrasting fabric.

- A) One fabric or leather for top panel
yardage: 1.75 yds. leather: 30.0 sq. ft.
- B) One fabric or leather for body
yardage: 2.65 yds. leather: 40.0 sq. ft.

Please specify the fabric or leather application by designating the appropriate letter on the purchase order.

colours 9 4839	16½"	59⅝"	59⅝"	45¾"	16½"	5.25 yds.	90.0'	81 lbs.	100.22' / 1
	419 mm	1514 mm	1508 mm	1162 mm	419 mm	4.8 m	8.4 sqm	36.8 kg	2.84 cu.

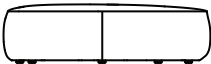
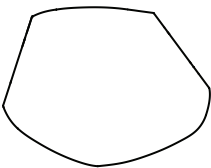

Level I and GREENGUARD Certified

Connecting module. Fully upholstered with saddle stitch detail. Fabric **Railroaded**. Leather has seamed top. When submitting COM, please provide a continuous roll of fabric in the total yardage for the configuration(s). Striped or plaid fabrics and certain patterns with distinct direction are not suitable for application. Solids, textures and leathers are recommended. *All **COM/COL** fabrics must be preapproved by Bernhardt Design prior to application.

When using a combination of fabrics or leathers, the following yardage must be used and upcharges apply. See terms and conditions for contrasting fabric.

- A) One fabric or leather for top panel
yardage: 2.0 yds. leather: 32.0 sq. ft.
- B) One fabric or leather for body
yardage: 3.6 yds. leather: 65.0 sq. ft.

Please specify the fabric or leather application by designating the appropriate letter on the purchase order.

	Seat Height	Max Dim.	W	D	H	Fabric	Leather	Weight	Cubes/Qty
colours 10 4840	16½"	66¾"	65⅝"	42¾"	16½"	3.6 yds.	65.0'	88 lbs.	80.67' / 1
	419 mm	1695 mm	1667 mm	1086 mm	419 mm	3.3 m	6.0 sqm	40.0 kg	2.28 cu.

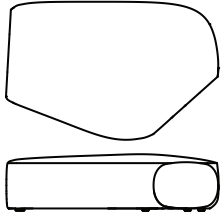

Level I and GREENGUARD Certified

Connecting module. Fully upholstered with saddle stitch detail. Fabric **Railroaded**. Leather has seamed top. When submitting COM, please provide a continuous roll of fabric in the total yardage for the configuration(s). Striped or plaid fabrics and certain patterns with distinct direction are not suitable for application. Solids, textures and leathers are recommended. *All **COM/COL** fabrics must be preapproved by Bernhardt Design prior to application.

When using a combination of fabrics or leathers, the following yardage must be used and upcharges apply. See terms and conditions for contrasting fabric.

- A) One fabric or leather for top panel
yardage: 1.75 yds. leather: 30.0 sq. ft.
- B) One fabric or leather for body
yardage: 2.6 yds. leather: 40.0 sq. ft.

Please specify the fabric or leather application by designating the appropriate letter on the purchase order.

colours 11 4841	16½"	42¾"	38½"	37¾"	16½"	3.75 yds.	70.0'	65 lbs.	30.47' / 1
	419 mm	1089 mm	978 mm	949 mm	419 mm	3.4 m	6.5 sqm	29.5 kg	.86 cu.

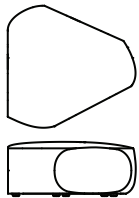

Level I and GREENGUARD Certified

Connecting module. Fully upholstered with saddle stitch detail. Fabric **Railroaded**. Leather has seamed top. When submitting COM, please provide a continuous roll of fabric in the total yardage for the configuration(s). Striped or plaid fabrics and certain patterns with distinct direction are not suitable for application. Solids, textures and leathers are recommended. *All **COM/COL** fabrics must be preapproved by Bernhardt Design prior to application.

When using a combination of fabrics or leathers, the following yardage must be used and upcharges apply. See terms and conditions for contrasting fabric.

- A) One fabric or leather for top panel
yardage: 1.75 yds. leather: 30.0 sq. ft.
- B) One fabric or leather for body
yardage: 2.75 yds. leather: 40.0 sq. ft.

Please specify the fabric or leather application by designating the appropriate letter on the purchase order.

colours 12 4842	16½"	70¾"	70¾"	41¼"	16½"	3.75 yds.	70.0'	85 lbs.	80.67' / 1
	419 mm	1797 mm	1797 mm	1048 mm	419 mm	3.4 m	6.5 sqm	38.6 kg	2.28 cu.

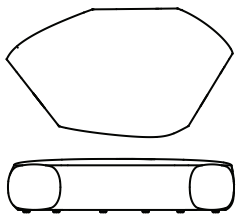

Level I and GREENGUARD Certified

Connecting module. Fully upholstered with saddle stitch detail. Fabric **Railroaded**. Leather has seamed top. When submitting COM, please provide a continuous roll of fabric in the total yardage for the configuration(s). Striped or plaid fabrics and certain patterns with distinct direction are not suitable for application. Solids, textures and leathers are recommended. *All **COM/COL** fabrics must be preapproved by Bernhardt Design prior to application.

When using a combination of fabrics or leathers, the following yardage must be used and upcharges apply. See terms and conditions for contrasting fabric.

- A) One fabric or leather for top panel
yardage: 2.0 yds. leather: 35.0 sq. ft.
- B) One fabric or leather for body
yardage: 2.75 yds. leather: 45.0 sq. ft.

Please specify the fabric or leather application by designating the appropriate letter on the purchase order.